

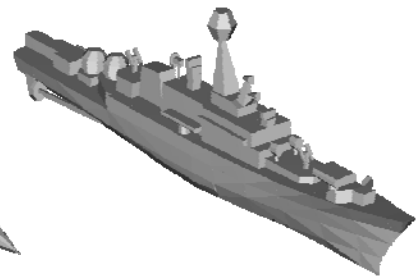

AVAL

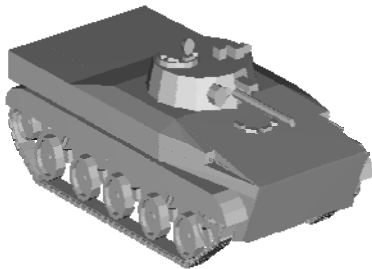
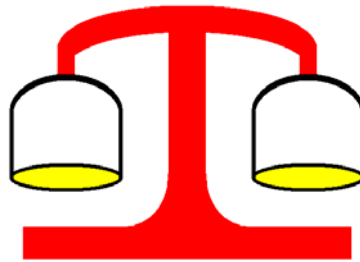

AVAL 6.6

User's Manual



AVAL 6.6

User's Manual



January 2008

All rights reserved
Swedish Defence Research Agency (FOI, Sweden)

www.foi.se/aval

aval@foi.se

Table of Contents

| | | |
|----------|--|-----------|
| 1 | General information | 7 |
| 1.1 | Identification | 7 |
| 1.2 | System overview | 7 |
| 1.3 | Documentation overview | 8 |
| 1.4 | Manual formats..... | 8 |
| 2 | Units, notations and coordinate systems | 9 |
| 2.1 | SI system..... | 9 |
| 2.2 | Material..... | 10 |
| 2.3 | Case | 10 |
| 2.4 | Coordinate systems..... | 10 |
| 2.4.1 | Warhead coordinate system | 10 |
| 2.4.2 | Warhead carrier coordinate systems | 11 |
| 2.4.3 | Target coordinate system..... | 11 |
| 2.4.4 | Interpolation in tables | 13 |
| 2.4.5 | Convex component geometry | 13 |
| 2.4.6 | Data file format | 13 |
| 2.4.7 | Max parameters | 13 |
| 3 | Modes of operation | 16 |
| 3.1 | Modes..... | 16 |
| 3.2 | Sub modes | 16 |
| 3.2.1 | Single shot simulation mode | 16 |
| 3.2.2 | Weapon lethality simulation mode | 16 |
| 3.2.3 | Target vulnerability simulation mode | 17 |
| 3.3 | Tools..... | 17 |
| 4 | Single shot simulation mode | 18 |
| 4.1 | Conventional warhead effects..... | 18 |
| 4.1.1 | Start the Single target program module | 18 |
| 4.1.2 | Select a target to be used | 18 |
| 4.1.3 | Select a warhead effect to be used..... | 18 |
| 4.1.4 | Specify method for calculating fragment hits on target..... | 20 |
| 4.1.5 | Specify the simulation situation..... | 21 |
| 4.1.6 | Specify the Target velocity, Start seed and Evaluation time..... | 22 |
| 4.1.7 | Specify the damage effects..... | 22 |
| 4.1.8 | Specify the output | 23 |
| 4.1.9 | Run the simulation | 23 |
| 4.1.10 | Display the result..... | 23 |
| 4.1.11 | Examine result text files | 26 |
| 4.2 | Laser weapon..... | 27 |



| | | |
|----------|---|-----------|
| 4.2.1 | Start the Single target program module..... | 27 |
| 4.2.2 | Select target..... | 27 |
| 4.2.3 | Select weapon | 27 |
| 4.2.4 | Define simulation | 28 |
| 4.2.5 | Run simulation | 29 |
| 4.2.6 | Examine result files..... | 29 |
| 4.3 | HPM weapon..... | 29 |
| 4.3.1 | Start the Single target program module..... | 29 |
| 4.3.2 | Select target..... | 29 |
| 4.3.3 | Select weapon | 30 |
| 4.3.4 | Define simulation | 30 |
| 4.3.5 | Run simulation | 31 |
| 4.3.6 | Examine result text files | 31 |
| 4.4 | Arena test..... | 31 |
| 5 | Weapon lethality simulation mode | 32 |
| 5.1 | Conventional warheads | 32 |
| 5.2 | Specify a warhead carrier | 32 |
| 5.3 | Specify a case..... | 33 |
| 5.4 | Define a simulation | 35 |
| 5.5 | Simulations with more than one case | 37 |
| 5.6 | Running the simulation | 37 |
| 6 | Target vulnerability simulation mode | 39 |
| 6.1 | Conventional warheads | 39 |
| 6.2 | Specify a case..... | 39 |
| 6.3 | Define a simulation | 40 |
| 6.4 | Running the simulation | 41 |
| 7 | APS simulation mode | 43 |
| 7.1 | The warhead carrier..... | 43 |
| 7.2 | The target..... | 44 |
| 7.3 | Burst point pattern..... | 44 |
| 7.4 | Running the simulation | 44 |
| 7.5 | Displaying results for a simulation | 44 |
| 8 | Consecutive calculations | 45 |
| 8.1 | Defining a consecutive simulation..... | 45 |
| 8.2 | Running a consecutive calculation..... | 45 |
| 8.3 | Displaying results..... | 46 |

| | | |
|----------|---|-----------|
| 9 | Single target menu | 47 |
| 9.1 | Target display customisation..... | 47 |
| 9.1.1 | Target windows | 47 |
| 9.1.2 | Change viewpoint..... | 47 |
| 9.1.3 | Wireframe view..... | 48 |
| 9.1.4 | Hidden line view | 48 |
| 9.1.5 | Shading view | 49 |
| 9.1.6 | Orthographic projection..... | 50 |
| 9.1.7 | Component colours | 50 |
| 9.1.8 | Background colour | 50 |
| 9.1.9 | Select target components | 50 |
| 9.1.10 | Select layers..... | 51 |
| 9.1.11 | Color by layer settings..... | 52 |
| 9.1.12 | Select transparent components | 52 |
| 9.1.13 | Select target volumes..... | 53 |
| 9.1.14 | Display components used in fault tree | 53 |
| 9.1.15 | Splinter generating surfaces | 54 |
| 9.1.16 | Co-ordinate axes..... | 54 |
| 9.1.17 | Spin geometry | 54 |
| 9.2 | Result presentation | 54 |
| 9.2.1 | Read simulation | 55 |
| 9.2.2 | Burst points | 55 |
| 9.2.3 | Grid..... | 55 |
| 9.2.4 | Vulnerability..... | 55 |
| 9.2.5 | Lethality | 56 |
| 9.2.6 | Time control..... | 56 |
| 9.2.7 | Remove | 56 |
| 9.3 | Arena test..... | 56 |
| 9.3.1 | Creating an arena test target | 56 |
| 9.3.2 | Simulating the arena test | 62 |
| 9.3.3 | Example of an arena test simulation..... | 62 |
| 9.4 | Create penetration criteria by help of simulations..... | 63 |
| 9.4.1 | The user input file..... | 63 |
| 9.4.2 | Simulations..... | 64 |
| 9.5 | Generation and modification of target data | 64 |
| 9.5.1 | Target | 64 |
| 9.5.2 | New component | 65 |
| 9.5.3 | Copy component | 67 |
| 9.5.4 | Delete component | 67 |
| 9.5.5 | Enable mouse selection | 67 |
| 9.5.6 | Select from list..... | 68 |
| 9.5.7 | Modify attributes | 68 |
| 9.5.8 | Modify co-ordinates..... | 68 |
| 9.6 | Test geometry | 69 |
| 9.6.1 | Calculate intersections | 69 |
| 9.6.2 | Plot intersections..... | 70 |



| | | |
|-----------|--|-----------|
| 9.6.3 | Intersection options..... | 71 |
| 9.6.4 | Check if all corner points are in a plane..... | 71 |
| 9.6.5 | Check thickness for all plane surfaces | 72 |
| 9.6.6 | Check internal protection | 72 |
| 10 | Generating weapon data | 74 |
| 10.1 | Sensors | 74 |
| 10.2 | Height (.hse)..... | 74 |
| 10.2.1 | Impact (.imp) | 74 |
| 10.2.2 | Laser (.las) | 75 |
| 10.2.3 | Proximity (.pro)..... | 75 |
| 10.2.4 | Time (.tim)..... | 76 |
| 10.2.5 | Active pulsed laser (.apl)..... | 76 |
| 10.2.6 | Magnetic (.mag) | 77 |
| 10.2.7 | Empirical IR (.eir) | 77 |
| 10.3 | Fuze system (.fze) | 78 |
| 10.4 | Warhead effect..... | 78 |
| 10.4.1 | Shaped charge (.sce)..... | 78 |
| 10.4.2 | Kinetic energy projectile (.kep) | 81 |
| 10.4.3 | Shaped charge with penetrating nose (.hnp)..... | 83 |
| 10.4.4 | Explosively formed projectile (.efp)..... | 83 |
| 10.4.5 | High explosive charge (.hex) | 85 |
| 10.5 | Warhead (.whd)..... | 86 |
| 10.6 | Warhead carrier (.wcf) | 86 |
| 10.6.1 | Data for critical events for a threat in an APS-simulation | 87 |
| 10.6.2 | Data for trajectory for a threat in an APS-simulation | 87 |
| 10.7 | Laser weapons (.law)..... | 87 |
| 10.8 | HPM weapons (.hpm) | 88 |
| 10.9 | EMP Weapons (.emp)..... | 89 |
| 11 | Tools | 91 |
| 11.1 | Change AVAL file name..... | 91 |
| 11.2 | Change AVAL file path used in input files..... | 92 |
| 11.3 | Generate fragment data (SPLITX or FRAGM)..... | 92 |
| 11.3.1 | Input data for SplitX | 93 |
| 11.3.2 | Input data for FragM | 94 |
| 11.3.3 | Generate fragment data (Experiments) | 96 |
| 11.4 | Edit..... | 97 |
| 11.4.1 | Edit material data | 97 |
| 11.4.2 | Edit penetration criterion | 98 |
| 11.4.3 | Edit pressure criterion | 98 |

| | | |
|-----------|-------------------------------------|-----------|
| 12 | Menu structure | 99 |
| 12.1 | AVAL main menu options..... | 99 |
| 12.2 | Single target menu options | 101 |
| 12.3 | Indirect fire map menu options..... | 105 |
| 12.4 | Direct fire scene menu options..... | 108 |
| 12.5 | Mine field map menu options | 110 |



1 General information

1.1 Identification

Since 1995 the model AVAL has been developed in Sweden and is presently used by government agencies and private industry in several nations. AVAL stands for Assessment of Vulnerability And Lethality.

AVAL is developed in close co-operation between:

- FMV (Defence Materiel Administration)
- FOI (Swedish Defence Research Agency)
- BAE Systems Bofors AB
- Dynamec Research AB.

AVAL is owned by the Swedish Armed Forces and is managed by FOI from 2007, earlier AVAL was managed by FMV.

1.2 System overview

The purpose of the model is to serve as an aid in assessment of platform vulnerability and weapon lethality. The Swedish national vision has been to achieve:

- Use of the same model by all parties involved in research, design, manufacturing and use of ordnance projects.
- A model that handles all kinds of targets and weapons.
- An object model, dealing with the product properties vulnerability and lethality and including all important phenomena for the product, capable of producing data for combat models and make use of data from technology models.

The first part of this vision has from year 2002 been extended to include international parties.

The model is a commercially available, autonomous model designed for use with standard PC:s and standard office software. It consists of:

- Two executable codes:
 - AVAL.exe
 - AVALCAD.arx, a program extension to AutoCAD.
- Sample data for some warheads and targets.
- Documentation.

AVAL.exe is available with two additional optional functionalities:

- Indirect Fire including integrated lethality and ballistic calculations and map management
- AVAL.exe as a console application without the graphical interface.

AVAL is unclassified although specific assessment data and simulation results are often classified according to user.

The included data for warheads and targets are all based on open literature. They do not represent any specific intelligence knowledge and do not represent any Swedish governmental opinion on design and performance.

1.3 Documentation overview

AVAL ST (Single Target) documents:

- User Manual
- Reference Manual
- Target Description Manual
- File formats document
- Sample and generic descriptions (Warheads and Targets)

The User Manual describes units, conventions and how to operate AVAL.

The Reference Manual describes how the different phenomena are calculated, how the model parameters are defined and how they are specified as the input data.

The Target Description Manual describes the format and contents of a target description including how to use AVALCAD.

The file format document describes formats for a selection of input and output files. File formats not included are those for weapon data that is defined in the user interface and for target data that are described in the Target Description Manual.

Sample and generic descriptions consists of documents and data for some warheads and targets intended to show the content of different types of descriptions or for generic use.

Additional AVAL ST+IF (Single Target plus Indirect Fire) documents:

- User Manual Indirect Fire
- User Manual MAPS
- Ballistics Reference Manual

The User Manual Indirect fire describes the format and contents of an indirect fire scene and how to run an artillery simulation.

The User Manual Maps describes requirements, conventions and how to use maps in AVAL.

The Ballistics Reference Manual describes how the ballistic phenomenon is calculated and how the model parameters are defined.

1.4 Manual formats

The following textformats are used in this maual to increase the readability:

file names and extensions are written with *Times new roman, bold, italic, 12 pt*

menu options, clickable buttons and radio chek buttons are written with **Arial, bold, 10pt**.



2 Units, notations and coordinate systems

2.1 SI system

All calculations in AVAL is based on a strict use of the SI system and all input data are given in this system with only a few exceptions (degrees instead of radians in some dialogue boxes which is clearly marked). No units are specified in the dialogue boxes except when SI units not are used. Table 1 give some of the most used SI units:

Table 1: The most used SI units.

| Variable | Unit | Name |
|------------------|-------|--------------------|
| Length | m | meter |
| Time | s | second |
| Velocity | m/s | meters per second |
| Mass | kg | kilogram |
| Angle | rad | radian |
| Angular velocity | rad/s | radians per second |
| Frequency | 1/s | Hertz |

As a support when transferring angles in degrees to radians Table 2 is given. Eq. (1) shows the relations between degrees and radians.

$$1 \text{ deg} = \frac{\pi}{180} \text{ radians} \approx 0.0175 \text{ radians} \quad \text{Eq. (1)}$$

Table 2: Degrees and radians

| Degrees | Radians |
|---------|---------|
| 10 | 0.1745 |
| 20 | 0.3491 |
| 30 | 0.5236 |
| 40 | 0.6981 |
| 45 | 0.7854 |
| 50 | 0.8727 |
| 60 | 1.0472 |
| 70 | 1.2217 |
| 80 | 1.3963 |
| 90 | 1.5708 |

| | |
|-----|--------|
| 100 | 1.7453 |
| 110 | 1.9199 |
| 120 | 2.0944 |
| 130 | 2.2689 |
| 135 | 2.3562 |
| 140 | 2.4435 |
| 150 | 2.6180 |
| 160 | 2.7925 |
| 170 | 2.9671 |
| 180 | 3.1416 |

2.2 Material

The properties of the materials used in each target are specified in a material data file, included in the target description. The specified mass protection factors are valid only if the penetration data, specified for each warhead effect, are given for the reference material Mild steel.

2.3 Case

The term case is used frequently in this manual. A case is in AVAL-terms part of a simulation specification. The case describes which warhead carrier, target and ground conditions that will be used.

2.4 Coordinate systems

2.4.1 Warhead coordinate system

The warhead- and warhead effect coordinate system is orientated so the x-axis is pointing forward, the y-axis to the right and the z-axis towards earth, which is right handed system.

When a warhead effect is inserted in a warhead the following data are used for position the effect in warhead coordinate system (X_w, Y_w, Z_w):

- x_{pe} Position for the warhead effect origin along the warhead x-axis.
- ψ_e Rotation of warhead effect around the z-axis, see Figure 1.
- Θ_e Rotation of warhead effect around the rotated y-axis, see Figure 1.

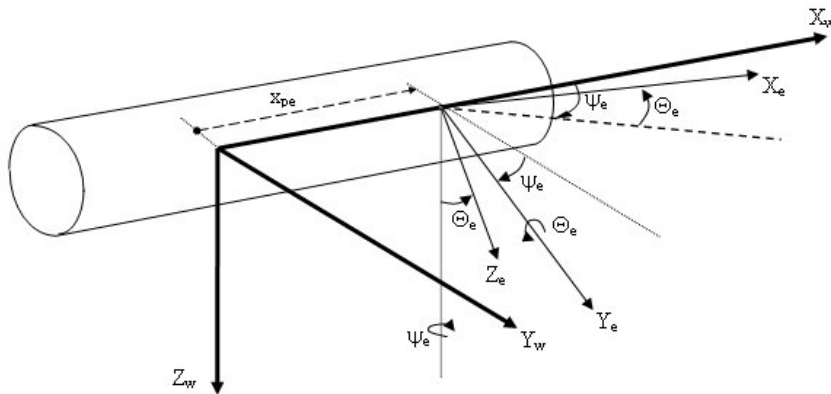

Figure 1 The warhead coordinate system

2.4.2 Warhead carrier coordinate systems

The warhead carrier coordinate system is also right handed defined in similar way as the warhead and warhead effect.

When a warhead is inserted in a warhead carrier the following data are used for transformations to warhead carrier coordinate system (X_{wc}, Y_{wc}, Z_{wc}):

- x_{pw} Position for the warhead origin along the warhead carrier x-axis.
- y_{pw} Position for the warhead origin along the warhead carrier y-axis.
- z_{pw} Position for the warhead origin along the warhead carrier z-axis.
- ψ_w Rotation of warhead around the z-axis, see Figure 2.
- Θ_w Rotation of warhead the rotated y-axis, see Figure 2.

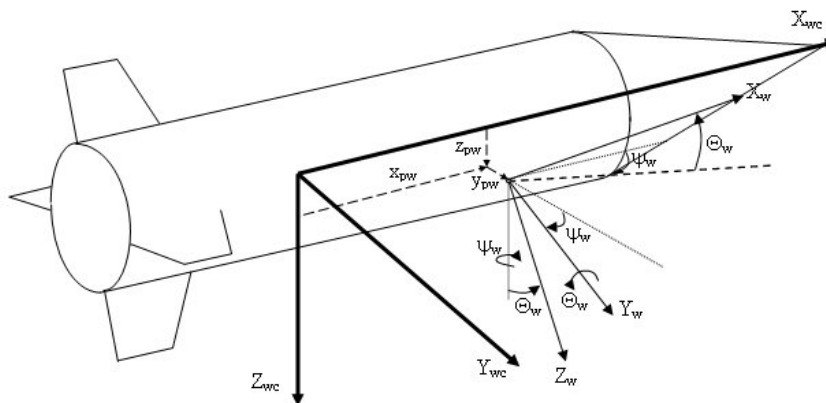

Figure 2 The warhead carrier coordinate system

2.4.3 Target coordinate system

The target co-ordinate system has its x-axis directed from the front towards the rear of the target, the y-axis points through the right hand side (starboard) of the target and the z-axis upwards, Figure 3.

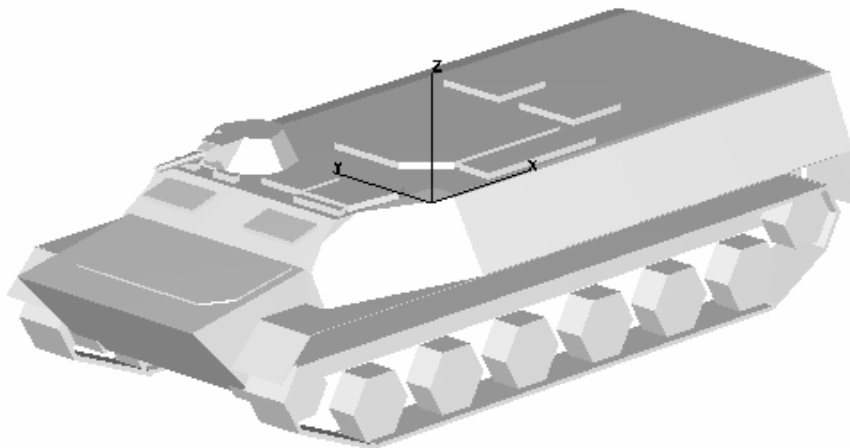

Figure 3 The target coordinate system

The position of the warhead effect in a single warhead effect simulation specifies the reference point of the warhead effect in the target coordinate system.

The direction of the warhead effect in a single warhead effect simulation is specified by the x-, y- and z-components in the target coordinate system of a vector along the warhead effect direction. The vector needs not to be normalized to a unit length.

The warhead effect velocity is assumed to be aligned with its direction and the target velocity is positive when the target moves forward (along its negative x-axis).

The roll angle is always given in the warhead carrier coordinate system.

The firing direction when generating hit points from the Case and Single Shot dialogue boxes is specified in relation to the target coordinate system by two angles, Figure 4:

- Psi (ψ): the rotation angle for warhead carrier around targets z-axis, see Figure 4. The angle is measured from targets positive x-axis. A positive ψ -value means rotation counter clockwise around targets z-axis. If the ψ -value is zero the x-axis for both target and warhead carrier are aligned, but the y- and z-axis are pointing in opposite directions.
- Theta (Θ): the rotation around rotated y-axis for the warhead carrier, see Figure 4. The angle is measured from the xy-plane of the target coordinate system. OBSERVE: A positive Θ -angle means attacking target from below and negative Θ -angle from above.

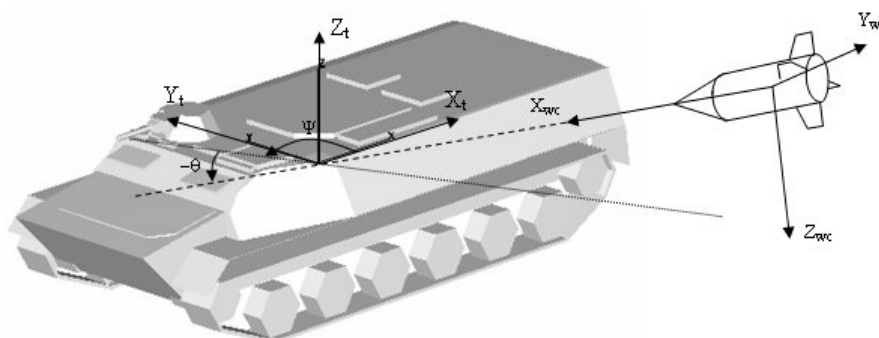



Figure 4 The target/warhead carrier coordinate system

2.4.4 Interpolation in tables

Linear interpolation is used in all tables defined. When the interpolation variable is outside the limits the program is using the nearest value in table. No extrapolation is used.

2.4.5 Convex component geometry

All components must be convex, in order to avoid the possibility for a penetrator to be entering, exiting and again entering the same component, which AVAL can not handle. A component which is concave (in reality) should be "split up" in two (or more) parts which can be described in AVAL as convex. When describing a vital component with more than one vital component it is important to take the damage criterion in consideration. The incapacitation probability for damage criterion for heat, smoke and pressure may increase with increasing number of components (see chapter 7 in the Target description manual).

2.4.6 Data file format

The data text input/output files are in a free format, which means that the separations between values are either space, tab or comma.

In some cases there are more data in the text file than was entered in the dialogue box. In these cases the dialogue box has "greyed out" text boxes, which means that there should not be data specified, but data (zeroes) is written for that "greyed out" text box in the text file anyway. If you are working in text files and find values hard to understand, please open the file in AVAL to make sure that that data corresponds to a "greyed out" text box.

2.4.7 Max parameters

The reason for choosing max parameters is to avoid a dynamic allocation of memory, which makes the software slower. The values are put according to an assumed need, and they can be increased by the developers when there is a need for it.

Table 3 shows the maximum number of different parameters that are not within input data.

Table 3: Max number of (parameters not within input data)

| | |
|---|------------|
| Characters in a line in an input/output file | 500 |
| Plotted hits (entering and exiting a component) for each MonteCarlo cycle | 32767 |
| Calculated splinter generated surfaces for each penetrator | 10 |
| Integration variable for calculation of atmosphere turbulence | 5 |
| Integration variables for calculation a projectile trajectory | 12 |
| Trig points for all sensors in a warhead carrier | 10 |
| Damage criteria for a vital component | 14 |

Table 4 shows the maximum number of different parameters that are within input data.

Table 4: Max number of (parameters within input data)

| | |
|---|------------|
| Characters allowed in a title | 100 |
| Values allowed in a atmosphere table in the .atm -file | 1000 |
| Range tables (....skv -files) allowed in the .tab -file | 100 |
| Aim instrument range tables allowed in the .ain -file | 50 |
| Aim points allowed in the .ain -file | 100 |
| Sets for aim accuracy allowed in the .ain -file | 100 |
| Velocity marks allowed in the .ain -file | 50 |
| Distance marks allowed in the .ain -file | 100 |
| Velocity choices allowed in the .ain -file | 50 |
| Distance choices allowed in the .ain -file | 200 |
| Velocity intervals allowed in the .ain -file | 50 |
| Distance intervals allowed in the .ain -file | 100 |
| Intuitive sight values allowed in the .ain -file | 20 |
| Values allowed in table for manual estimation of range in the .tmm -file | 100 |
| Sensors allowed in a fuze in the .fze -file | 20 |
| Points allowed for defining impact sensors (.imp -file) and proximity sensors (.pro -file) | 50 |
| Lasers allowed in an active pulsed laser sensor in the .apl -file | 50 |
| "Fields of view" allowed in an active pulsed laser sensor in the .apl -file | 50 |
| Detectors allowed in an active pulsed laser sensor in the .apl -file | 50 |
| Evaluation blocks allowed in an active pulsed laser sensor in the .apl -file | 50 |
| Micro lobes describing the laser in an active pulsed laser sensor allowed in the .apl -file | 10 |
| Rays allowed in a microlobe in the .apl -file | 100 |
| Filters acting on the detector signal allowed in the .apl -file | 50 |
| High filters allowed in a detector in the .apl -file | 10 |
| Low filters allowed in a detector in the .apl -file | 10 |
| Geometry files for vital components (.vtg -files) and structure components (.otg -files) respectively, allowed in a target (.trg -file) | 100 |
| Protection modules (ERA and LRA) allowed in a target respectively | 500 |



| | |
|--|-------|
| Liner types allowed in a target's liner file (.lnr) | 10 |
| Materials allowed in a target's material file (.mtl -file) | 70 |
| Impact angles for protection factors allowed in a target's material file (.mtl -file) | 20 |
| Layers allowed, that components can be connected to, in a target | 500 |
| targets (including trees, stones etc) allowed to be used in a scene (.scn -file) | 400 |
| Components allowed to describe a scene (.otg -file), excluding trees, stones etc which are defined as targets | 30000 |
| Impact angle values allowed for a penetrating warhead carrier (.mrp -file) | 20 |
| Impact velocity values allowed for penetrating warhead carrier (.mrp -file) | 20 |
| Reduction factors allowed for penetrating warhead carrier (.mrp -file) | 10 |
| Splinter cone angles allowed for penetrating warhead carrier (.mrp -file) | 10 |
| Splinter distribution values allowed for penetrating warhead carrier (.mrp -file) | 10 |
| Warhead effects allowed in a warhead (.whd -file) | 7 |
| Warheads (.whd -files) allowed in a warhead carrier (.whc -file) | 20 |
| Evaluation times allowed in a simulation | 10 |
| Cases (.lcs -file or .vcs -file) allowed in a simulation file (.lsm -file or .vsm -file) | 10 |
| Simulations (.lsm -file or .vsm -file) allowed in a consecutive simulation (.csm -file) | 2000 |
| Laser signatures (.bmp -file) allowed in a target's (.sel -file) | 10 |
| Events in the fault tree (.syc -file) | 5000 |
| Events in a multi outcome event, in the fault tree (.syc -file) | 200 |
| Operator events in each event, in the fault tree (.syc -file) | 500 |
| Probabilities for each multi outcome event, in the fault tree (.syc -file) | 20 |
| The maximum number of hollow polyhedrons to build up a tank | 20 |
| The maximum number of panels for structural damage in each tank | 20 |

3 Modes of operation

3.1 Modes

The AVAL software package contains several separate main modes. The main modes are:

- Single target mode. In the Single target mode simulations are performed on a single target with a warhead carrier. The following sub modes are available:
 - Single shot simulation mode
 - Weapon lethality simulation mode
 - Target vulnerability simulation mode
- Indirect fire mode (optional). In the Indirect fire mode simulations are performed on a scene containing a map, multiple targets, weapon systems and observer. Simulations are performed with a complete weapon platform. The following sub mode is available:
 - Weapon lethality simulation mode
- Console mode (optional). The Console mode is a separate, AVAL executable file corresponding to AVAL 6 ST (Single Target) but without the graphical interface. The exe-file requires the same hard lock device as AVAL 6 ST.
 - Weapon lethality simulation mode
 - Target vulnerability simulation mode

3.2 Sub modes

3.2.1 Single shot simulation mode

In this mode the effect of one single interaction between a target and a warhead effect is assessed. The simulation can be performed with a single warhead effect, a warhead containing several warhead effects or a complete warhead carrier containing one or more warheads and a fuze system. The user specifies the target and the warhead to be used, the aim point and the moving direction of the warhead effect, the velocity of the warhead effect and the target, the damage effects to be active and the time after which the effect in the target shall be presented. The result of the interaction can be presented in great detail like the trajectory and hit points of all primary and secondary penetrating objects, the effect on each vital component from any of the damage effects, the time history of the time dependent phenomena etc.

3.2.2 Weapon lethality simulation mode

This is one of the two “production type” modes and it is used to assess the average effect of a weapon, fired with a realistic hit distribution, on a target, using the Monte Carlo technique (repeated interaction simulations and averaging of the result). The weapon is represented by a warhead carrier, containing a fuze system and one or several warheads, each containing one or several warhead effects. The trajectory distribution and the corresponding hit point distribution can be generated by a built in simulation module or by importing data from some external source. AVAL calculates the effect of each weapon carrier hit, stores the effect on the target performance together with a number of intermediate data and analyses the result statistically. After the simulation the result of the entire hit distribution can be displayed graphically as well as presented in text files used for continued analyses.



3.2.3 Target vulnerability simulation mode

The third mode differs from the weapon lethality mode in the type of hit distribution and in the way the result of the simulation is presented while the target and the warhead carrier are specified in the same way. The user defines an aim point, a firing direction and also a regular, rectangular grid (number of grid points and grid cell sizes in side and height and the number of warhead carriers to be fired in each grid cell). The reason for choosing more than one hit in each grid cell is to avoid large random result differences due to edge effects etc. AVAL locates the grid in a plane through the aim point, perpendicular to the firing direction. The points where each of the trajectories for the warhead carrier that shall be fired against each of the grid cells cut the grid plane may be randomly chosen by AVAL inside the cell and the hit points for the warhead carriers following each of the trajectories are calculated. AVAL simulates the effect of each hit, calculates an average over the hits inside each grid cell and can present the result graphically as a topographic map showing the effect in each grid position in a colour scale. Of course all results are also stored in text files for further analyses.

3.3 Tools

Besides these three sub modes of operation, the AVAL package contains a number of supporting tools, which permit the user to perform activities like:

- generate sensor, fuze system, warhead effect, warhead and warhead carrier data
- import fragmentation warhead data from different sources and generate input data in AVAL format
- build simple targets (e.g. test site plate targets) and simulate warhead tests in order to adjust the input data for the best representation of test results
- modify and to some extent build target descriptions
- test target descriptions for consistency regarding component intersections, surface planarity and internal protection data
- change file names and file paths in AVAL files
- convert target descriptions from AVAL 5 to AVAL 6 format

These additional options are only briefly described below.

4 Single shot simulation mode

The single shot simulation is performed in the Single target mode and the result is graphically displayed. Calculation results are also written in a text file. You work with already created weapon and target data.

The single shot simulation can be of two kinds:

- Simulation with either, a conventional weapon effect, a warhead with one or more warhead effects or a complete warhead carrier with a fuze system and one or more warheads where you use only one Monte Carlo cycle.
- Simulation with EM (Electro Magnetic) weapons where any number of Monte Carlo cycles may be used.

For simulation with conventional weapon effects you will be instructed how to:

- start the Single target program module
- select a target
- select a warhead effect
- define the location, direction, velocity and roll angle of the warhead effect
- define the target velocity, evaluation time and random number start seed
- select the damage effects you want to be active
- fire the warhead effect
- evaluate the result by the Single target program
- examine the generated text files.

For simulation with EM weapons you will be instructed how to:

- start the Single target program module
- select a target
- select an EM weapon
- specify input data for the simulation
- run the EM weapon simulation
- examine result text files.

4.1 Conventional warhead effects

4.1.1 Start the Single target program module

Start AVAL. Open the pull down menu **Modes** and click on **Single Target....** . An empty window (Target No. 1) is opened.

4.1.2 Select a target to be used

Open the pull down menu **Target** and then click on **Read target....** . The dialogue box Open Target File is opened. Find and choose the *.trg* file of the target you want to use.

Adjust the orientation, size and view of the target by using the mouse or Camera options (see chapter 9.1 Target display customisation).

4.1.3 Select a warhead effect to be used

Open the pull down menu **Single simulation** and then click on **Single shot....** . The dialogue box Single shot simulation, Figure 5, is opened.

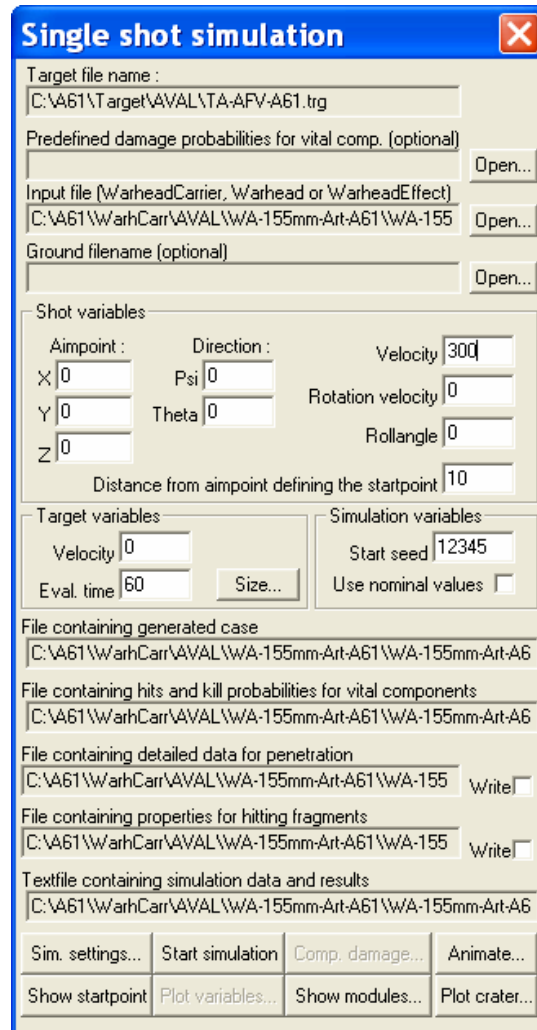

Figure 5: The single shot simulation dialog box.

Move it to a suitable location on the screen.

Special feature: Click on the first **Open...** key to open a file with predefined damage probabilities for vital parts.

This is only for the special situation when you have results from other simulations or tests that you want to incorporate in your simulation.

Click on the second **Open...** key to open a warhead carrier or single weapon effect to simulate.

The dialog box Open warhead carrier is opened. Find and choose the file you want to use among files with the following file extensions:

Warhead carrier with warheads and fuzes:

- Warhead carrier file *.wcf*

Warhead with warhead effects:

- Warhead *.whd*

Single warhead effects:

- Shaped charge: *.sce*
- Hard nose: *.hnp*
- Kinetic energy: *.kep*
- EFP: *.efp*
- Fragment: *.frg*
- High explosive: *.hex*

Special feature: Click on the third **Open** key to open a ground file (*.gnd*).

A ground file is needed to simulate the active pulsed laser sensor and otherwise optional. The ground will not be visible in the single target mode but will generate burst points if hit.

The format of a *.gnd*-file is similar to a *.trg*-file, se example below.:

```
'Ground surface'           ! Ground name
10   1  'C:\A66\DF\Scene\Ground\Ground_nn.otg' ! Geometry
500  0  'C:\A66\DF\Scene\Ground\LaserSign.sel' ! Laser signature
500  0  'C:\A66\DF\Scene\Ground\Ground_nn.otg' ! Layer data
```

4.1.4 Specify method for calculating fragment hits on target

If a warhead effect containing fragment data is selected, two options are available for calculating fragment hits on target. Depending on the case, the Optimized option can reduce the simulation time dramatically. Click on the button **Options for fragment hit calc...**, then the following dialogue box is opened, Figure 6.

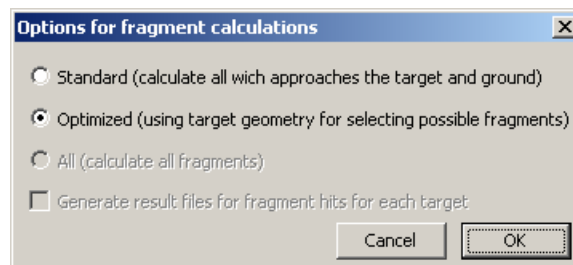

Figure 6: Options for fragment calculations

In this mode two options are possible:

Standard means that all fragments which approach the target are calculated. If the burst point is situated inside a sphere containing all target geometry all fragments are calculated until the leave the sphere or hits the target. If a ground is defined all fragments which approach the ground polygons also are calculated. Note that in reality hits by fragments may occur for fragments that initially are moving away from the target (high elevations).

If the radio button named **Optimized** is selected a more sophisticated selection method is used. A fragment which direction has a bearing which is between the bearings for target limitations (β_{\min} , β_{\max}) is selected, see Figure 7. The elevation angle for the fragment direction must be greater than the min elevation angle (θ_{\min}) in the Figure 7 below. The ground is not considered at all with this method. In this option all hits by fragments on targets are accounted for (also those with high elevations).

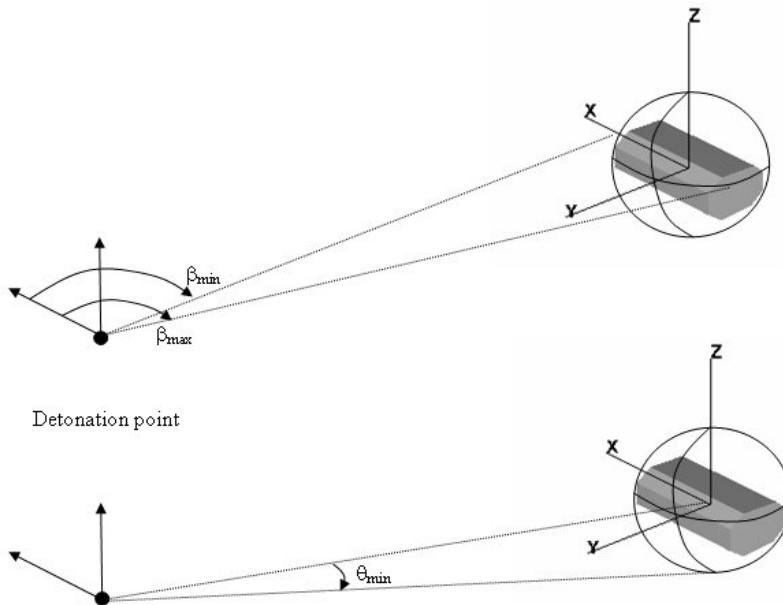

Figure 7 Limitations for bearing and elevation for fragment selection.

4.1.5 Specify the simulation situation

Specify the aim point, direction, velocity, roll angle and distance from the aim point for the Warhead effect.

The aim point and direction are related to the target co-ordinate system where ψ is the bearing anti clockwise from the x-axis and θ is the elevation from the horizontal plane.

The velocity is given along the specified direction.

The roll angle is of importance only for asymmetrical warhead effects and is related to the warhead effect co-ordinate system.

When defining aim point, firing direction and distance, AVAL calculates the location of the starting point. The starting point for a warhead carrier (which includes a fuze) must be located outside the radius of the smallest sphere (with origin in target origin), Figure 8, that contains the target completely. Note that the distance required does not guarantee that it is enough for the sensor. The starting point for Warheads and Warhead effects (without fuze) may be inside the sphere or even inside the target and for these the distance should be set to 0.

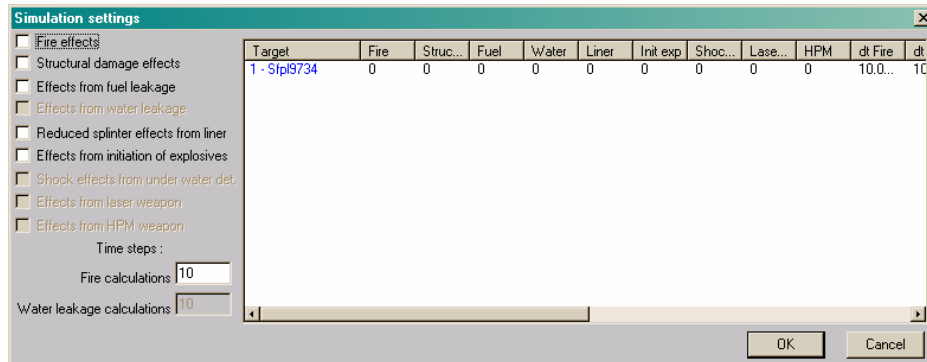

Figure 9: The Simulation settings dialogue box.

4.1.8 Specify the output

Check the two “write”-boxes, Figure 5, to specify that output.

All output is automatically located in the warhead directory. The following result files are or can be produced:

- A file containing the generated case is always created. This file can later be used to run a lethality simulation with the purpose to get a statistically safe result.
- A file containing damage to all components is always created. This file gives the number of hits in each vital component and the kill probabilities by different damage effects.
- A file containing detailed data for penetration is created if you check the **Write**-box. The file holds penetration data for every penetration that occurs in the simulation also from secondary splinters. The file can be used for detailed penetration studies and includes incapacitation of the penetrated vital component.
- A file containing properties for hitting fragments is created if you check the **Write**-box. The file can be used for detailed fragment studies and includes fragment and hit data.
- A file containing simulation data and results is always created. The file holds information about the simulation, all input and all output of the simulation (except for the graphic results).

4.1.9 Run the simulation

Click on the **Start simulation** key to start the calculation.

When the calculation is finished the plot is automatically changed to display the position of the warhead effect, the trajectory of each penetrating object from the warhead effect and each generated secondary fragment and each hit point on component surfaces. All vital parts that are damaged by any damage effect are shown in red.

4.1.10 Display the result

4.1.10.1 Damage type

Click on the **Comp. damage...** key, Figure 5. The Select damage type dialogue box, Figure 10, is opened with a long list of options with corresponding check boxes. By marking one or several of the boxes you can specify the conditions used by the program to display vital parts in red.

Every time you have changed any check box you have to click on the **Update plot** key to activate the plot.

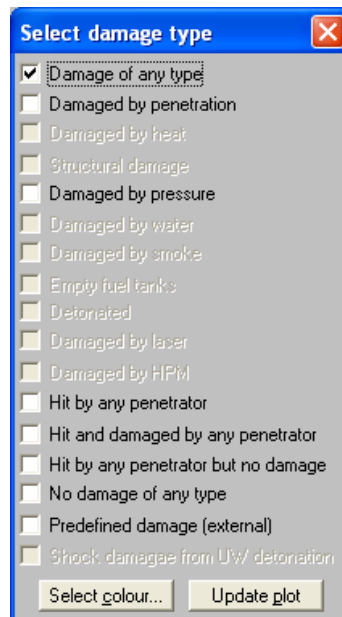

Figure 10: The Select damage type dialogue box.

If you want to change the default red colour used to mark the damaged vital parts, click on the **Select colour...** key, Figure 10. The Select colour dialogue box is opened and you can modify the colour with the sliding indicators. When you are finished, close the dialogue box with the **X** in the top, right corner.

When you have found the combination of damage effects and other conditions you want to use for the plot, close the Select damage type dialogue box with the **X** in the top, right corner. The selected conditions will be used until you change them or until you close the Target program.

4.1.10.2 Penetrating objects

By default the trajectories and hit points of all penetrating objects are shown in the plot; different colours for the different types of objects. This may block part of the plot too much and you have the option to hide or change the size or colour of the trajectories and hit points. To do so click on the **Plot variables...** key, Figure 5, or open the pull down menu **MC simulation**, select **Burst point** and then click on **Set plot variables....** The Set plot variables dialogue box, Figure 11, is opened showing a list of penetrating objects applicable to the type of warhead effect you have chosen.

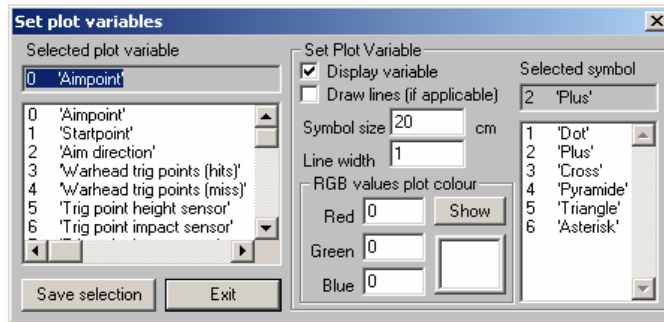

Figure 11: Set plot variables dialogue box.

Click on one of the list items and choose if you want it to be displayed at all (**Display variable**), if its trajectory shall be displayed (**Draw lines (if applicable)**), which size the hit point shall have (Symbol size) and in which colour it should be displayed (write an intensity value between 0 and 255 for each of the colours Red, Green and Blue, check the colour by clicking on the **Show** key). When you are satisfied with the settings for the chosen list item, click on the **Save** selection key and go to the next list item. When you are satisfied with all settings, close the Set plot variables dialogue box by clicking on the **Exit** key.

4.1.10.3 Plot crater

The following dialogue, Figure 12, appears:

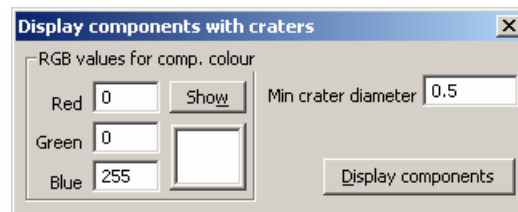

Figure 12: Plot crater dialogue.

Surfaces with craters with a diameter greater or equal the specified value is displayed with a selected colour. This plot is removed when the dialogue is closed.

4.1.10.4 Show time histories

If Fire effects, Effects from water leakage or HGV (Hull Girder Vibration) has been included in **Settings...** the development and damage versus time of these phenomena can be presented graphically. Click on the **Animate...** key and the Time control dialogue box, Figure 13, is opened.

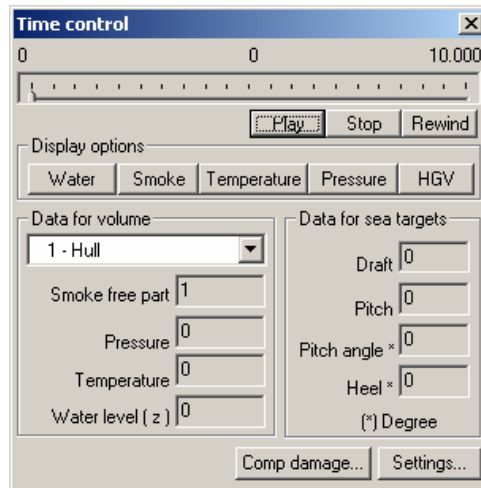

Figure 13: Time control dialogue.

First click in the Target window to connect the Time control dialogue box to that Target window (you may have several Target windows open and one Time control dialogue box can control all the Target windows).

Next select the effect to be displayed by clicking on the corresponding key in the Time control box (**Water**, **Smoke**, **Temperature**, **Pressure** or **HGV**). If you select **Temperature** or **Pressure** you can adjust the scale for the variable by clicking on the **Settings...** key. The Settings dialogue box for the selected variable is opened. If you have selected Temperature to be displayed the Settings dialogue box give you the option of changing the upper limit of the temperature scale either by writing a value in the box or by clicking on the **<Max in target** key. If you instead have selected Pressure to be displayed you may change both the lower and upper limit of the pressure scale in the Settings dialogue box. You can also set for how many time steps after an explosion the pressure will be displayed. If you leave the number to the default value 1 the pressure display may be too short to be seen. Accept the settings by clicking on the **OK** key.

The time history for the selected variable can now be displayed in colour either by moving the sliding index with the mouse cursor, by clicking on the time scale or by clicking on the **Play** key. The **Stop** key will freeze the display and the **Rewind** key will move the index to time 0.

In the lower left corner you may select one of the volumes (see the Target Description Manual about volumes) in the target and get the variable values in numbers at the current time step.

The lower right corner is used by the program to present the current Draft, Pitch, Pitch angle and Heel values if the water leak phenomenon is set.

With the **Comp damage...** key you can select the condition on which the marking of damaged vital part shall be based in the same way as in the Warhead effect dialogue box.

When you have finished the display of the time histories, just close the Time control dialogue box with the **X** at the top right corner.

4.1.11 Examine result text files

The **.txt**-file file containing simulation data and results gives you the information on the status of the target in terms of what has happened to target systems and capabilities. Since only one simulation is done the resulting probability is always 0 or 1.



The files with the extension *.skv* can be examined using Excel. If you chose to open with Excel you normally get the information as a text string in the first worksheet column. Use the Excel capacity in Data/Text to columns to transform to columns.

Formats for all files are specified in the File format document.

4.1.11.1 End the simulation session

We have now covered all menu options that are unique for the Single shot simulation mode. You may also use the other available general options on the menu to adjust the displayed plot, identify components with mouse clicks etc. These options are discussed in chapter 9.1 Target display customisation and chapter 9.2 Result presentation.

You may open several completely independent Target windows by opening the pull down menu Window and then click on **New window**. When you want to close the Target windows, be sure to close all open dialogue boxes first.

4.2 Laser weapon

4.2.1 Start the Single target program module

Start AVAL. Open the pull down menu **Modes** and click on **Single Target.....** An empty window (Target No. 1) is opened.

4.2.2 Select target

Open the pull down menu **Target** and then click on **Read target.....** The dialogue box Open Target File is opened. Find and choose the *.trg* file of the target you want to use.

Adjust the orientation, size and view of the target by using the mouse or Camera options (see chapter 9.1 Target display customisation).

4.2.3 Select weapon

Open the pull down menu **Single simulation** and select **EM weapons** and **Laser** and then click on **Simulate.....** The dialogue box Laser weapon simulation is opened, Figure 14. Move it to a suitable location on the screen.

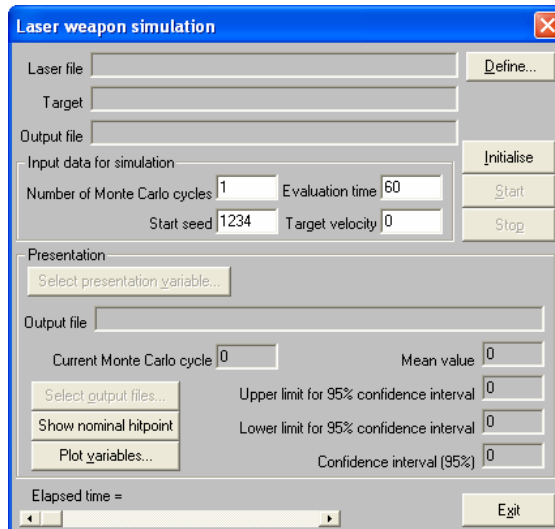

Figure 14: Laser weapon simulation dialogue box.

Click on the **Define** key. The dialogue box Open Laser weapon is opened.

Find and choose the laser weapon file you want to use. The file extension is **.law**.

Click in the target area (Target No. 1) to update the Laser weapon simulation dialogue box with target information.

The name of the output file will appear automatically in the window Output file when the simulation is started.

4.2.4 Define simulation

Specify the Number of Monte Carlo cycles, Evaluation time, Start seed and Target velocity.

The number of Monte Carlo cycles affects the statistical quality of the results.

Evaluation time defines the time after the burst/hit of the weapon effect at which the target status is evaluated.

The start seed is used by the random number generator.

Target velocity is positive along the negative X-axis of the target co-ordinate system.

Example:

| | |
|--------------------|-------|
| Monte Carlo cycles | 100 |
| Calculation time | 60 |
| Start seed | 12345 |
| Target velocity | 0 |

Click the **Initialise** key to make AVAL read the data you have chosen. When this is done you have access to keys in the field Presentation.

Click the **Select presentation variable...** key. The dialogue box Plot variables is opened and you can choose the Top event and the evaluation time for the results that will be shown in the Laser weapon simulation dialogue box during the simulation. Even if you do not conduct this step, data for all events are saved and available for later evaluation and examination.



Click the **Select output files...** key. The dialogue box Output files is opened and you can choose what output files you want to create during the simulation. The available choices are the same as for a lethality simulation; see chapter 5.4 Define a simulation. If you do not conduct this step, only mandatory output files are created.

Click the **Show nominal hit point** key to show the direction from where the laser weapon is fired and the point in the target that is hit when the beam travels towards the hit point (The hit point is input data for the laser weapon, see chapter 10.7 Laser weapons (.law)).

4.2.5 Run simulation

Click on the **Start** key to start the simulation. As the simulation proceeds the number of the current Monte Carlo cycle and the elapsed time is shown. To the right is shown the current mean value and its confidence interval. Simultaneously you can watch the target window where the hit points for the laser beams are shown for the current Monte Carlo cycle. Nominal hit points are shown as crosses and beam hit points are shown as points. Vital parts that are damaged are shown in red from the cycle they are damaged. This means that at the end of the simulation you can see what vital parts have been damage with any probability more than 0.

4.2.6 Examine result files

All result files are located in the current Laser weapon directory. The Output file (.txt) summarises:

- all settings and conditions for the simulation,
- probabilities for all events in the fault tree
- name and location of other output files with one exception (see below).

In the file ending with *...Effect.skv* the outcome for each top event for each Monte Carlo cycle and time is recorded. In the file *....skv* the data for the chosen event and time in the Laser weapon simulation dialogue with its mean value and confidence data is recorded. This file is the exception mentioned above.

Other result files that can be created are the same as for a lethality simulation and are described in the File format document.

4.3 HPM weapon

4.3.1 Start the Single target program module

Start AVAL. Open the pull down menu **Modes** and click on **Single Target.....** An empty window (Target No. 1) is opened.

4.3.2 Select target

Open the pull down menu **Target** and then click on **Read target.....** The dialogue box Open Target File is opened. Find and choose the *.trg* file of the target you want to use.

Adjust the orientation, size and view of the target by using the mouse or Camera options (see chapter 9.1 Target display customisation).

4.3.3 Select weapon

Open the pull down menu **Single simulation** and select **EM weapons** and **HPM** and then click on **Simulate...** The dialogue box HPM weapon simulation, Figure 15, is opened.

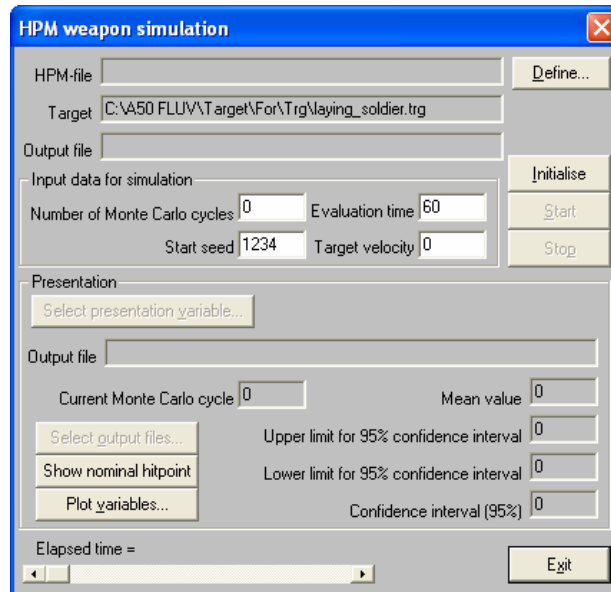

Figure 15: HPM weapon simulation dialogue box.

Move it to a suitable location on the screen.

Click on the **Define...** key. The dialogue box Open HPM weapon is opened. Find and choose the HPM weapon file you want to use. The file extension is **.hpm**.

Click in the target area (Target No. 1) to update the HPM weapon simulation dialogue box with target information.

The name of the output file will appear automatically in the window Output file when the simulation is started.

4.3.4 Define simulation

Specify the Number of Monte Carlo cycles, Evaluation time, Start seed and Target velocity.

The number of Monte Carlo cycles affects the statistical quality of the results.

Evaluation time defines the time after the burst/hit of the weapon effect at which the target status is evaluated.

The start seed is used by the random number generator.

Target velocity is positive along the negative X-axis of the target co-ordinate system.

Example:

- Monte Carlo cycles 100
- Evaluation time 60
- Start seed 12345
- Target velocity 0



Click the **Initialise** key to make AVAL read the data you have chosen. When this is done you have access to keys in the field Presentation.

Click the **Select presentation variable...** key. The dialogue box Plot variables is opened and you can choose the Top event and the evaluation time for the results that will be shown in the HPM weapon simulation dialogue box during the simulation. Even if you do not conduct this step, data for all events are saved and available for later evaluation and examination.

Click on the **Select output files...** key. The dialogue box Output files is opened and you can choose what output files you want to create during the simulation. The available choices are the same as for a lethality simulation, see chapter 5.4 Define a simulation. If you do not conduct this step, only mandatory output files are created.

Click on the **Show nominal hit point** key to show the direction from where the HPM weapon is fired and the point in the target that is hit when the radiation field travels towards the hit point (The hit point is input data for the HPM weapon, see chapter 10.8 HPM weapons (.hpm)).

4.3.5 Run simulation

Click on the **Start** key to start the simulation. As the simulation proceeds the number of the current Monte Carlo cycle and the elapsed time is shown. To the right is shown the current mean value and its confidence interval. Simultaneously you can watch the target window where the hit points for the HPM radiation fields are shown for the current Monte Carlo cycle. Nominal hit points are shown as crosses and radiation field hit points are shown as points. Vital parts that are damaged are shown in red from the cycle they are damaged. This means that at the end of the simulation you can see what vital parts have been damage with any probability more than 0.

4.3.6 Examine result text files

All result files are located in the current HPMr weapon directory. The Output file (.txt) summarises:

- all settings and conditions for the simulation,
- probabilities for all events in the fault tree
- name and location of other output files with one exception (see below).

In the file ending with *...Effect.skv* the outcome for each top event for each Monte Carlo cycle and time is recorded. In the file *....skv* the data for the chosen event and time in the HPM weapon simulation dialogue with its mean value and confidence data is recorded. This file is the exception mentioned above. See File format document.

Other result files that can be created are the same as for a lethality simulation.

4.4 Arena test

See chapter 9.3 Arena test.

5 Weapon lethality simulation mode

The weapon lethality simulation mode is one of the main simulation modes available in AVAL. It is performed from either the single target program module or the indirect fire program module. The results can be studied in the single target program module or the indirect fire program module respectively for easy viewing. In this chapter we assume that warhead data as well as target data exist. In chapter 10 Generating weapon data you will learn how to generate your own warhead data. Targets are generally more complicated to generate and are therefore treated in a separate manual. In this chapter you will be instructed how to:

- specify a warhead,
- specify a lethality case and
- run the simulation.

5.1 Conventional warheads

A warhead in AVAL consists of several parts: sensor(s), fuze(s), warhead effect(s) and a warhead carrier. All are selected from the warhead carrier pull down menu. A complete warhead carrier with sensors, fuzes, warhead effects and warheads can be saved for easy use.

5.2 Specify a warhead carrier

If a warhead carrier file already exists you can go directly to the next section. However, it is only possible to review the content of a warhead carrier from the Warhead carrier... dialogue. Therefore it is a good idea to go through the steps in this section.

Open the pull down menu **Warhead carrier** and then click on **Warhead carrier....** The Define warhead carrier dialogue box, Figure 16, is opened.

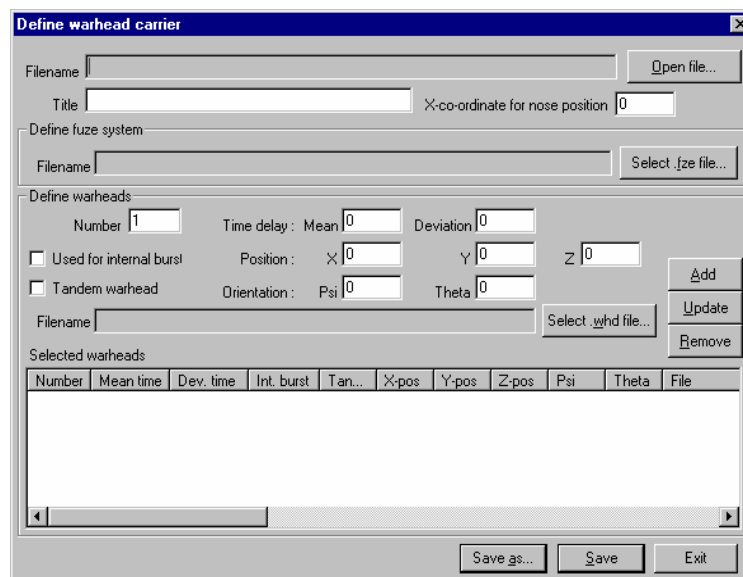

Figure 16: The Define warhead carrier dialogue box.

Choose **Open file**. The warhead carrier directories are usually saved in the WarhCarr directory. Choose a warhead carrier file (*.wcf*) and open it.



In the now filled dialogue box you can see the filename of the warhead carrier file and the title given to it, the fuze system file and a list of the warhead(s) carried in the warhead carrier.

5.3 Specify a case

This is where you specify which warhead carrier, target and ground condition that will be used.

Open the pull down menu **Modes** and click on **Single Target...** An empty window (Target No. 1) is opened. Open the pull down menu **MC simulation** and select **Crate case** and then click on **Lethality...** The Lethality case- Warhead carrier against single target dialogue box is opened, Figure 17.

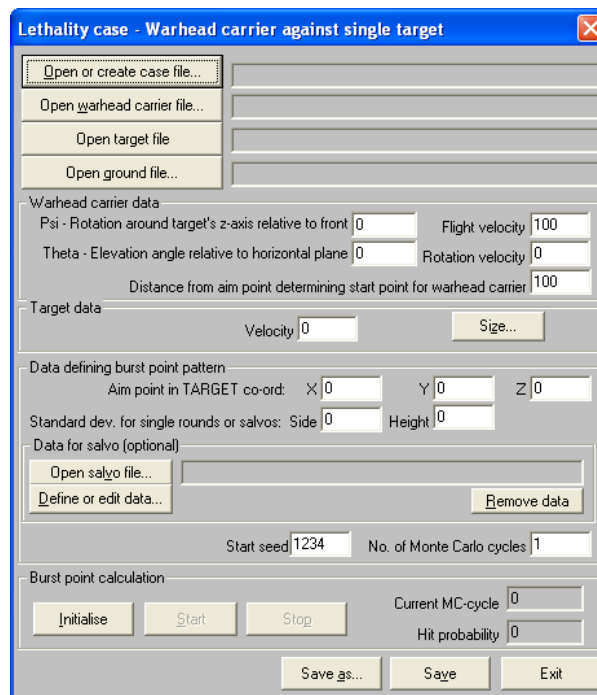

Figure 17: The Lethality case-Warhead carrier against single target dialogue box.

First click on **Open or create case file...** You can choose to either open an existing case file or create a new one. The file will be a lethality case file (*.lcs*). Then click on **Open warhead carrier file...** to select the warhead carrier to be used in the simulation.

Choose a target by clicking on **Open target file...** and open the desired target.

OPTIONAL. In some cases you may want to use specific ground conditions. If that is the case you can do this by clicking on **Open ground file...** and selecting the desired file. It is, however, optional and it is not necessary to use a ground file at all unless the fuze contains a sensor of type active pulsed laser.

Now you need to specify the direction and velocity of the warhead carrier. You specify angles Psi and Theta (in radians) relative to the target co-ordinate system. Flight velocity (m/s) and Rotation velocity (radians/s) are specified in the warhead carrier's co-ordinate system. You may also give the target a velocity.

You are still in the Lethality case dialogue box, Figure 17, and need to set some values for the interaction between warhead carrier and target. Specify the aim point in target co-

ordinates. This is aided by using the **Size...** button to ensure that the aim point lies within the target.

The distance from aim point determining start point for warhead carrier is used to make sure that the sensors and fuze systems have the time/distance needed to sense the target (see chapter 4.1.5 Specify the simulation situation).

Standard deviations are used to simulate the variation in hit point pattern when several shots are fired at the same aim point.

Optional a salvo file can be defined where number of salvos in each Monte Carlo cycle is given. The dialogue box for salvo data is shown in Figure 18.

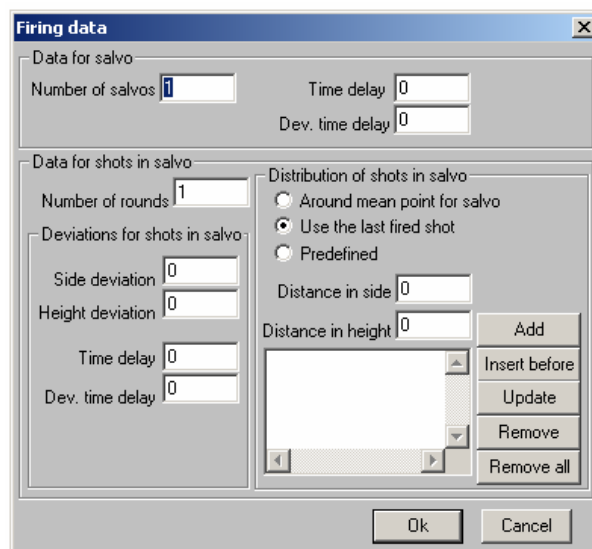

Figure 18: The firing data dialogue box to define salvos.

The standard deviations explained above are used to simulate the variation in hit point pattern for each salvo. Number of shots in each salvo is given along with standard deviations for each shot. The deviations for each shot can be relative the salvo hit point or the hit point of the last shot. The variation of shot hit points can also be given in a specific predefined pattern around the salvo hit point.

By specifying the Number of Monte Carlo cycles you specify how many times the simulation will be performed. If Standard deviations are 0 the hit point will be the same in all cycles.

You also need to specify a Start Seed for the calculation. This is used in the random number generation. If you run the simulation several times with the same Start Seed (and all other input data kept the same), you will get identical results.

Initialise the burst point calculation by clicking **Initialise**. After initialisation, clicking **Start** runs the burst point calculation. You can follow the calculation by Current MC-cycle and Hit probability.

When the calculation is finished, the case file is automatically read and the target and burst points are plotted.

Save the data and close the dialogue box.



5.4 Define a simulation

This is where you specify the case(s) to be simulated, the startseed, the damage effects to be included, the time(s) for which the lethality is evaluated and also what output files you want to produce when you run the simulation.

Open the pull down menu **MC simulation** and select **Simulation** and **Lethality** and then click on **Define...** The Define lethality simulation dialogue box, Figure 19, is opened.

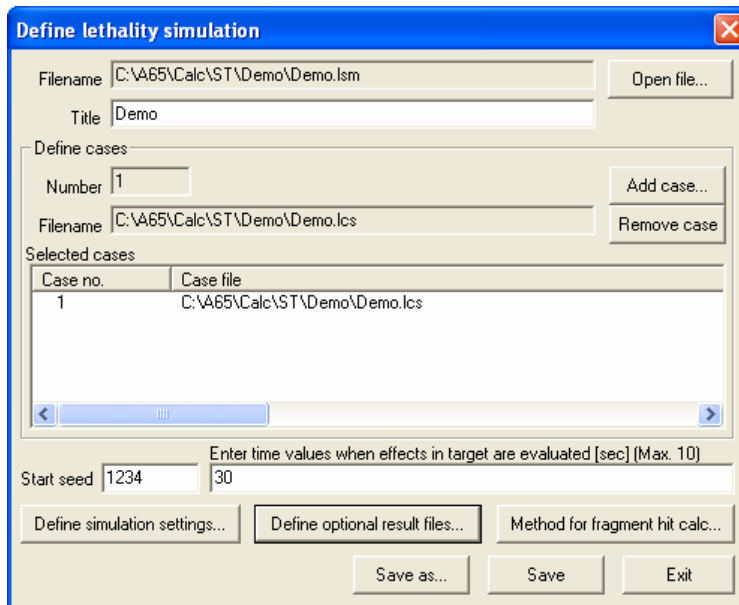

Figure 19: The Define lethality simulation dialogue box.

Click on **Open file...** to either open an existing simulation file or create a new one. This file (*.lsm*) will hold all data for the simulation. You can also give this file a descriptive title in the Title-field.

Add one or more case(s) to your simulation by clicking **Add case...** and selecting a lethality case file (*.lcs*). If you need to remove a case, select the case in the case list by clicking its number. Then click the **Remove case** button to remove the case from the simulation.

You need to specify a Start seed and times when you want to evaluate damage effects in the target.

Click on the **Simulation settings...** button to open the Simulation settings dialogue box, Figure 20.

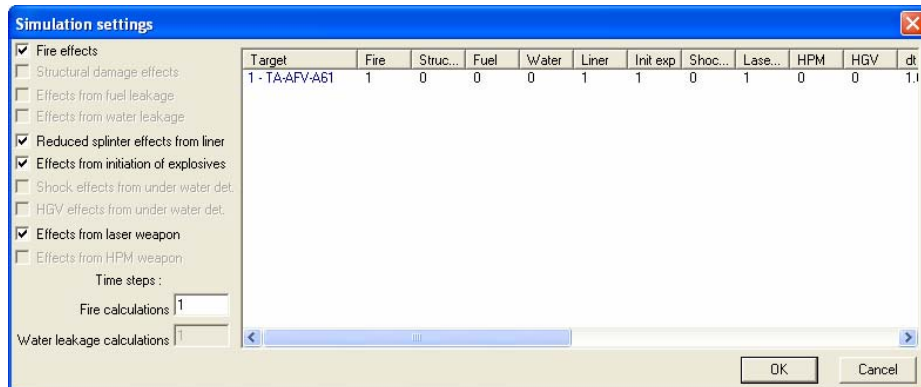

Figure 20: The Simulation settings dialogue box.

You can select the damage effects that you want to include in the simulation by clicking in the corresponding check box. Only those effects for which the target description contains data are available for selection. You can also set the time steps to be used for fire and water leakage calculations. If both fire and water leakage effects are included in the simulation, the smallest time step of the two will be used. Close the dialogue box by clicking **OK** when you are finished or click **Cancel** to cancel any selections.

Click on **Define optional result files...** to choose optional output files, Figure 21, to the standard result files.

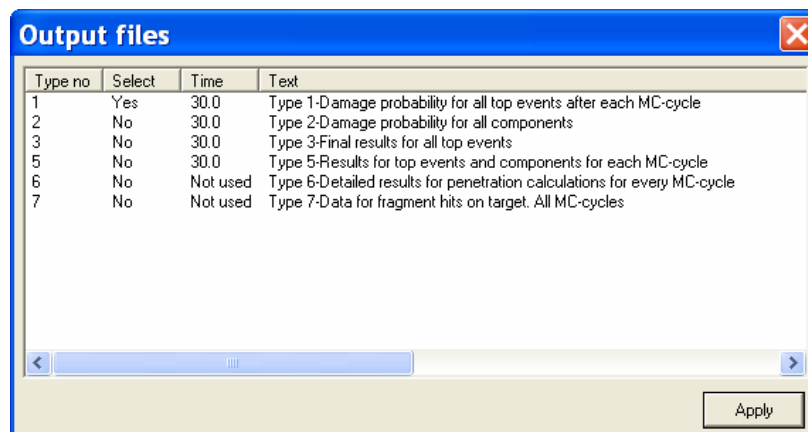

Figure 21: The Output files dialogue box.

Click on one of the numbers **1-7** in the field “Type no” to change “Select” from No to Yes or Yes to No.

Be careful when you specify Type 6 because it can produce a huge amount of data. Test with a simulation with one MC-cycle to start with! When Not used is shown in the Time column it indicates that data in the simulation does not admit the actual type of result. Content in the result files is described in the File format document.

Click on **Method for fragment hit calc...** to choose Standard or Optimized fragment calculations, Figure 22, (see chapter 4.1.4 Specify method for calculating fragment hits on target).

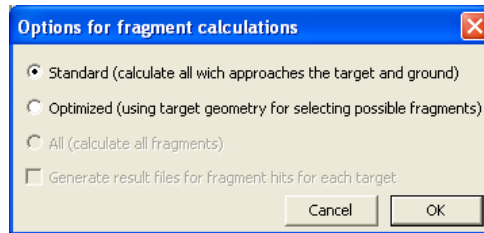

Figure 22: Options for fragment calculations.

Save the weapon lethality simulation file and close the dialogue box.

5.5 Simulations with more than one case

When simulations are defined with more than one case, the cases must contain the same number of MC cycles. When simulating, the effect of each MC cycle in all cases are calculated collectively.

Example, see Figure 23:

Three cases with 10 MC cycles are defined. No salvos are defined so each MC cycle in each case file is one shot (KE). In all cases the firing is from the side, but the aim points are different for the three cases.

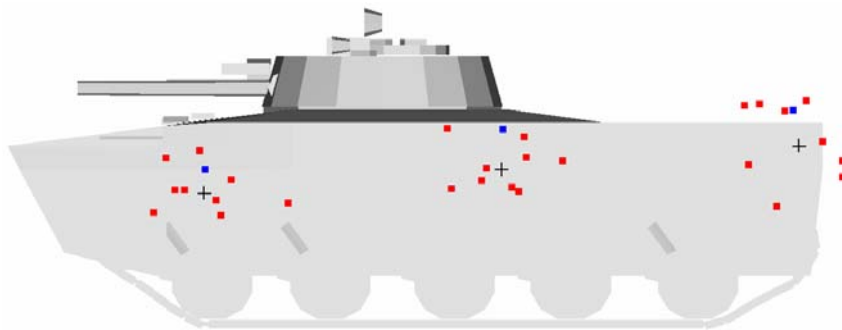

Figure 23: Shots at three different aim points (three cases).

In the simulation each MC cycle in all cases are calculated together, and the result (incapacitated or not) is representing the effect of all three shots.

5.6 Running the simulation

Open the pull down menu **MC simulation** and select **Simulation** and **Lethality** and then click on **Simulation...**. The Lethality simulation dialogue box, Figure 24, is opened. Click the **Select input file...** button and select the desired simulation file.

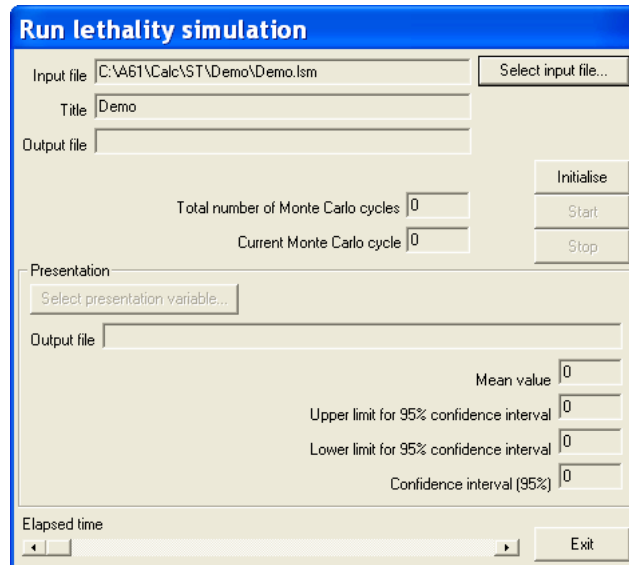

Figure 24: The Lethality simulation dialogue box.

Click **Initialise** to initialise the simulation. This step will check that all necessary data are present in the simulation file and create the default output file.

In another default text file, always created during a warhead lethality simulation, the probabilities for all top events at all specified evaluation times for every separate Monte Carlo cycle are stored. This file is used when plotting the simulation result in the Target module but it may also be examined by a text editor. Its name is automatically set to the following combination: The lsm-file *name* + *Effect* + *N.skv*, where *N* is increased by one every time the same *.lsm*-file is run. An example of this file is also shown in the File format document.

You can select a variable to study during the simulation by clicking **Select presentation variable...** and selecting an event and an evaluation time. The average value and the upper and lower limit of the 95% confidence interval are shown in text boxes, successively updated as the simulation proceeds. These values are also stored in a text file; which name ends with *...LethPlot.skv*, which may be used for plotting purposes. An example of this file is also shown in the File format document.

Start the simulation by clicking **Start**. When the calculation is finished, the case file is automatically read and the target and burst points are plotted. You can graphically display what hits have caused different events to happen at different times, see also chapter 9.1 and 9.2. Exit the dialogue box by clicking **Exit**.



6 Target vulnerability simulation mode

The target vulnerability simulation mode is one of the main simulation modes available in AVAL. The results can be studied in the single target program module for easy viewing. In this chapter we assume that warhead data as well as target data exist. In chapter 10 you will learn how to generate your own warhead data. Targets are generally more complicated to generate and are therefore treated in a separate manual.

Target vulnerability simulations are done by firing a warhead in a grid pattern, layed out on the target. This will give an indication of the target vulnerability in different location on the target and ballistic holes can be identified. In this chapter you will be instructed how to

- specify a target vulnerability case and
- run the simulation.

6.1 Conventional warheads

The warhead data is handled in exactly the same way for weapon lethality and target vulnerability simulation modes. Therefore there is no need to create different warheads for the different simulation modes. For information on warhead data see chapter 10.

6.2 Specify a case

This is where you specify which warhead carrier, target and ground condition that will be used. Open the pull down menu **MC simulation** and select **Create case** and then click on **Vulnerability....** The Vulnerability case (burst point calculation) dialogue box, Figure 25, is opened.

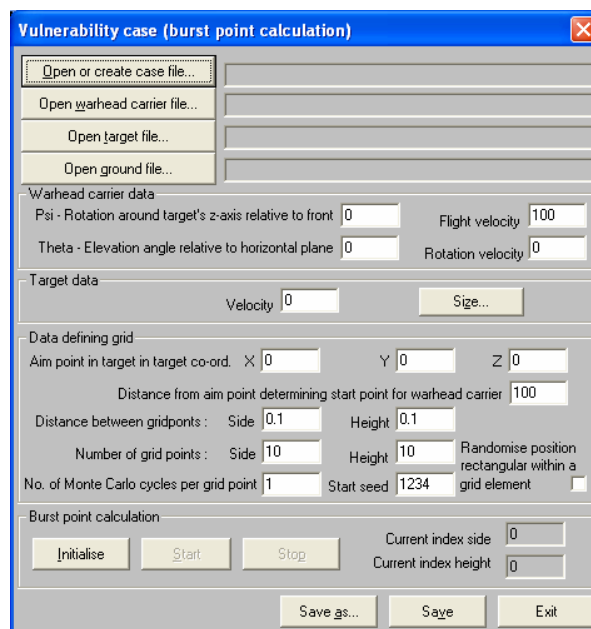

Figure 25: The Vulnerability case (burst point calculation) dialogue box.

First click on **Open or create case file...** You can choose to either open an existing case file or create a new one. The file will be a vulnerability case file (**.vcs**).

Then click on **Open warhead carrier file...** to select the warhead carrier to be used in the simulation.

Choose a target by clicking on **Open target file...** and open the desired target.

OPTIONAL. In some cases you may want to use specific ground conditions. If that is the case you can do this by clicking on **Open ground file...** and selecting the desired file. It is, however, optional and it is not necessary to use a ground file at all.

Now you need to specify the direction and velocity of the warhead carrier. You specify angles Psi and Theta (in radians) relative to the target co-ordinate system. Flight velocity (m/s) and Rotation velocity (radians/s) are specified in the warhead carrier's co-ordinate system.

You may also give the target a velocity.

You are still in the Vulnerability case dialogue box, Figure 25, and need to set some values for the interaction between warhead carrier and target.

Specify the aim point in target co-ordinates. This is aided by using the **Size...** button to ensure that the aim point lies within the target.

The distance from aim point determining start point for warhead carrier is used to make sure that the sensors and fuze systems have the time/distance needed to sense the target.

Next is the specification of the grid. The grid is specified by the size of grid elements and the number of grid points. The centre of the grid is the aim point.

By specifying the Number of Monte Carlo cycles per grid point you specify how many times the simulation will be performed in each grid point. By also selecting **Randomise position rectangular within a grid element** each grid point simulation will give slightly different hit points and an averaged result in each grid point.

You also need to specify a Start Seed for the calculation. This is used in the random number generation. If you run the simulation several times with the same Start Seed (and all other input kept the same), you will get identical results.

Initialise the burst point calculation by clicking **Initialise**. After initialisation, clicking **Start** runs the burst point calculation. You can follow the calculation by Actual index side and Actual index height.

When the calculation is finished, the case file is automatically read and the target and burstpoints are plotted.

Save the data and close the dialogue box.

6.3 Define a simulation

This is where you specify which case is going to be simulated and which damage effects are of interest.

Open the pull down menu **MC simulation** and select **Simulation** and **Vulnerability** and then click on **Define....** The Define vulnerability simulation dialogue box, Figure 26, is opened.

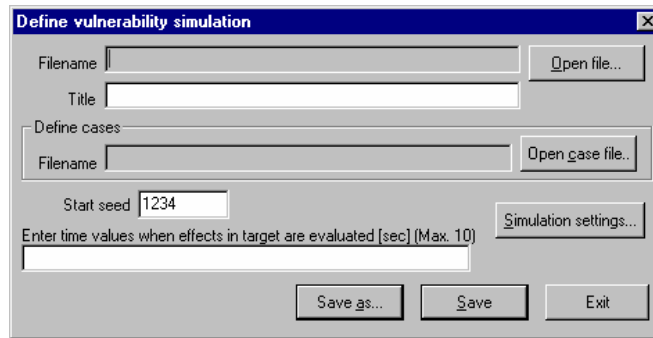

Figure 26: The Define vulnerability simulation dialogue box.

Click on **Open file...** to either open an existing simulation file or create a new one. This file (*.vsm*) will contain the case of interest and the simulation settings. You can also give this file a descriptive Title in the Title-box.

Add one case to your simulation by clicking **Open case file...** and select a vulnerability case file (*.vcs*).

You need to specify a Start seed and times when you want to evaluate damage effects in the target.

Click on the **Simulation settings...** button to open the simulation settings dialogue box, Figure 27. You can select the damage effects you want to be active during the simulation by clicking in the corresponding check box. Only those effects for which the target description contains data are available for selection. You can also set the time steps to be used for fire and water leakage calculations. If both fire and water leakage effects are included in the simulation, the smallest time step of the two will be used. Close the dialogue box by clicking **OK** when you are finished or click **Cancel** to cancel any selections.

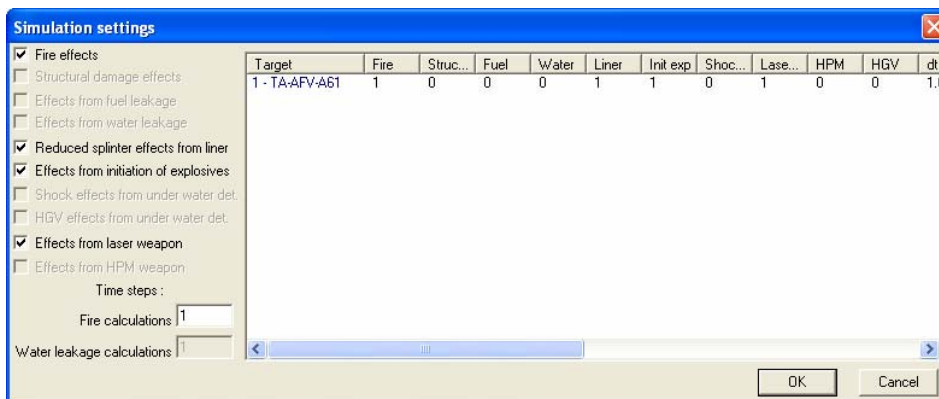

Figure 27: The Simulation settings dialogue box.

Save the target vulnerability simulation file and close the dialogue box.

6.4 Running the simulation

Open the pull down menu **MC simulation** and select **Simulation** and **Vulnerability** and then click on **Simulation...** The Vulnerability simulation dialogue box, Figure 28, is opened.

Open the desired simulation file by clicking the **Select input file...** button and select the desired file.

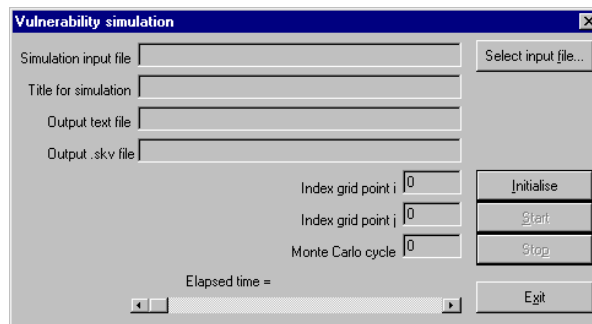

Figure 28: The Vulnerability simulation dialogue box.

Click **Initialise** to initialise the simulation. This step will check that all necessary data are present in the simulation file and create the default output files. Example of these files are shown in File format document

Start the simulation by clicking **Start**.

When the calculation is finished, the case file is automatically read and the target and burspoints are plotted.

Exit the dialogue box by clicking **Exit**

How to graphically study the results is described in detail in chapter 9.1 and 9.2.

A complete Monte Carlo simulation is performed for each gridpoint. Results for faulttree events are depending on time after the first hit in each gridpoint (reference time). The reference time is always derived from the shortest hitpoint in each gridpoint.



7 APS simulation mode

This mode is used for simulating an automatic protection system. In these calculations are the burst point and the lethality calculated simultaneous. The simulation is done in a dialogue with the following layout, Figure 29:

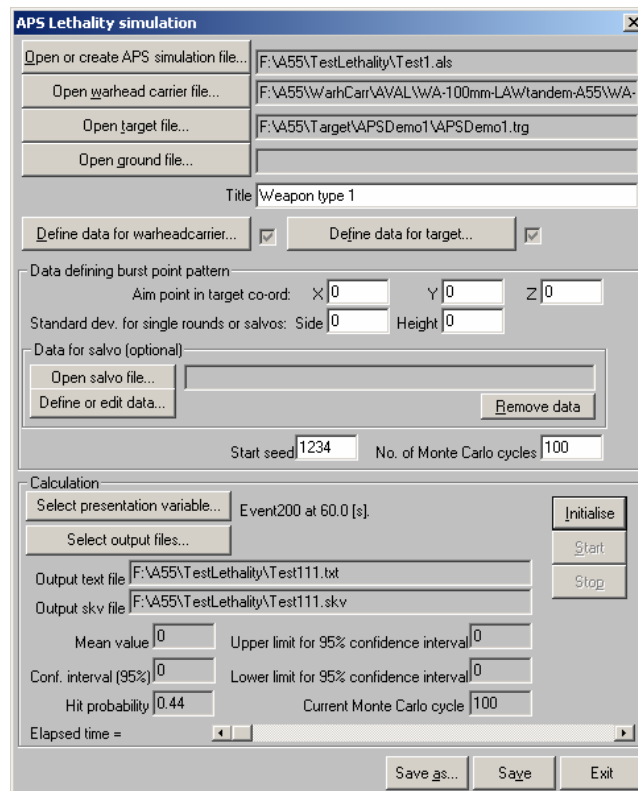

Figure 29: The APS Lethality simulation dialogue box.

7.1 The warhead carrier

The data for the warhead carrier must also contain:

- a file containing a target description for the warhead carrier according to AVAL:s nomenclature,
- a file containing data for critical events, format defined in chapter 10.6.1 and
- a file containing data for a trajectory, format defined in chapter 10.6.2.

When pressing the button **Define data for warheadcarrier** the following dialogue appear, Figure 30. In this dialogue is the firing direction defined in terms of Euler-angles. The simulation settings and time values are defined as usual.

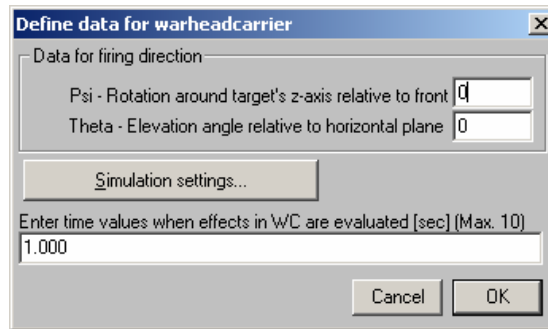

Figure 30: The Define data for warhead carrier dialogue box.

7.2 The target

The target description must contain a file with data for the APS, see Target Description Manual. When pressing the button **Define data for target** the following dialogue appear, Figure 31. In this dialogue are the velocity, time values and the simulation settings also defined.

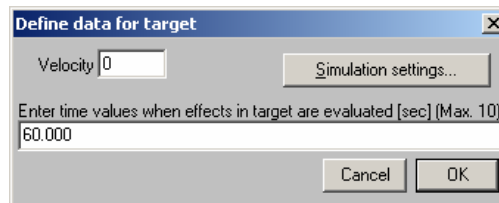

Figure 31: The Define data for target dialogue box.

7.3 Burst point pattern

There are still some values needed for the interaction between warhead carrier and target.

Specify the aim point in target co-ordinates.

Standard deviations are used to simulate the variation in hit point pattern when several shots are fired at the same aim point.

A salvo is optional for the calculation. If no salvo is select one shot is assumed per MC-cycle.

7.4 Running the simulation

Click **Initialise** to initialise the simulation. This step will check that all necessary data are present in the simulation file and create the default output file.

By clicking **Select output files...** you can select which additional output files you want to create.

7.5 Displaying results for a simulation

Burst points and lethality results can be displayed by graphics both for target and the warhead carrier. The target is always the default selection. The warhead carrier is selected or deselected by the menu command: **MC simulation** and **Select threat for APS simulation**.



8 Consecutive calculations

By defining and running a consecutive calculation, a number of simulations can be performed with no need for interference from the operator of AVAL. The consecutive calculation runs single cases and simulations in the order you define them.

8.1 Defining a consecutive simulation

Open the pull down menu **Modes** and click on **Single Target...** An empty window (Target No. 1) is opened.

Open the pull down menu **MC simulation** and select **Consecutive** and then click on **Define...** The Define consecutive calculation dialogue box, Figure 32, is opened.

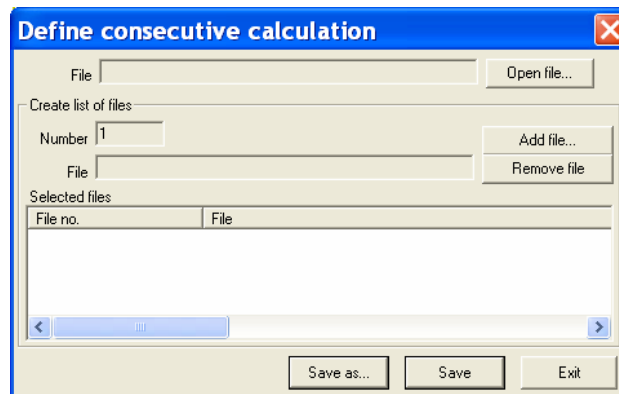

Figure 32: The Define consecutive calculation dialogue box.

Click on **Open file...** to either open an existing consecutive calculation file or to create a new one. This file (*.csm*) will contain the cases (*.lcs*, *.vcs*) and/or simulations (*.lsm*, *.vcm*) of your choice.

Add your cases and/or simulations by clicking **Add file...** and selecting a case file (*.lcs* or *.vcs*) or a simulation file (*.lsm* or *.vsm*). Repeat this for as many simulations that you want in the consecutive calculation file. The only thing you have to watch out for is that a case file producing input for a simulation must be listed before the simulation file.

If you need to remove a case or simulation file, select the case or simulation in the file list by clicking its number. Then click the **Remove file** button to remove the simulation from the consecutive simulation.

Save the consecutive calculation file and close the dialogue box.

8.2 Running a consecutive calculation

Open the pull down menu **MC simulation** and select **Consecutive...** and then click on **Run...** The Run consecutive calculation dialogue box, Figure 33, is opened.

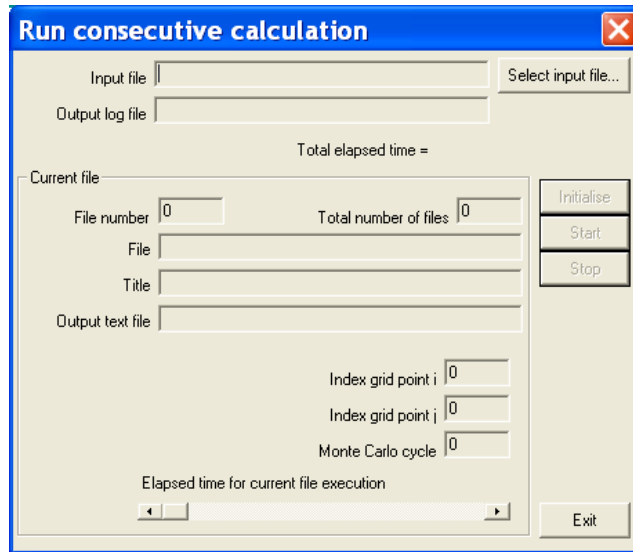

Figure 33: The Run consecutive calculation dialog box.

Open the desired consecutive calculation file by clicking the **Select input file...** button and select the desired file.

Click **Initialise** to initialise the consecutive calculation. This step will check that all necessary data are present in the consecutive calculation file and create the default output log file, see the File format document. The result files for the cases and the simulations will be located in the directories where the case file resides.

Start the calculation by clicking **Start**.

During the calculation session the totally elapsed time is shown. Current file (a case or a simulation) is identified by its number, name and title. The name of the standard output text file is shown. To show progress in the individual cases or simulations the current grid point and/or the current Monte-Carlo cycle is shown as well as the elapsed time. Should there be an error in a case or simulation file AVAL will skip this and go to the next file in the *.csm*-file. When the consecutive calculation is finished, exit the dialog box by clicking **Exit**.

8.3 Displaying results

The specific result from a consecutive simulation is only one file, (*.log*). See the File format document for description.



9 Single target menu

In this chapter we assume that target data and warhead data exist, as well as results from vulnerability and lethality simulations, except in the last section where you will learn to generate simple target data. In this chapter you will learn how to:

- Visualize a target
- Display simulation results
- Test a fragmenting warhead
- Generate and modify target data

9.1 Target display customisation

9.1.1 Target windows

Open the pull down menu **Modes** and click on **Single Target....** An empty window (Target No. 1) is opened.

Up to 10 target windows (Target No. 1 to 10) can be open at the same time. To open a new target window, open the pull down menu **Window** and click on **New window**.

To load target data in a target window, activate the target window by clicking on it, and open the pull down menu **Target** and then click on **Read target....** The dialogue box Open Target File is opened. Find and choose the *.trg* file of the target you want to use.

Target windows can be resized, maximized and minimized using the mouse as usual. To select a particular window, either click on its title bar or select it on the **Window** pull down menu. Cycle through all open windows by pressing Ctrl-Tab repeatedly.

To rearrange all windows with one on top of the other, click on **Cascade** on the **Window** pull down menu.

To arrange all windows side by side, click on **Tile** on the **Window** pull down menu.

Minimized windows are normally placed at the bottom of the AVAL main window. To rearrange all minimized window at the bottom of the main window, select **Arrange Icons** on the **Window** pull down menu.

In this chapter we will only use one single, maximized target window.

9.1.2 Change viewpoint

With target data loaded in a window, the target can be rotated, translated or zoomed using the mouse.

Hold down left mouse button and drag the mouse to rotate the target around the origin.

Hold down right mouse button and move the mouse up to zoom out the target, or down to zoom in the target.

Hold down the shift key and left mouse button and drag the mouse to move the target in the window.

For more accurate control of the viewpoint, use the Camera dialogue.

To open the Camera dialogue, Figure 34, open the pull down menu **Plot options** and then click on **Camera....**

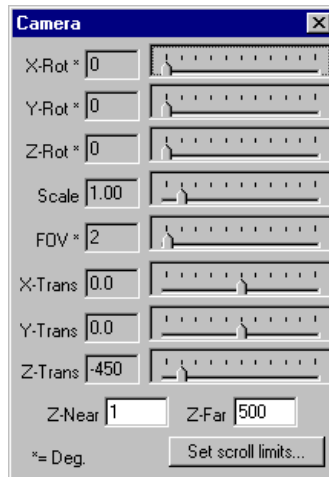

Figure 34: The Camera dialogue box.

Use the sliders to adjust the camera position. The first three sliders (X-Rot, Y-Rot and Z-Rot) rotate the camera around the target. X-Rot rotates the camera around a horizontal axes, Y-Rot rotates around an axes perpendicular to the screen, and Z-Rot rotates around a vertical axis.

The Scale slider sets the zoom factor and the FOV slider the field of view of the camera. Use these to adjust the size of the target.

The last three sliders (X-Trans, Y- Trans and Z- Trans) moves the camera horizontally, vertically and perpendicular to the screen, respectively.

The Z-Near and Z-Far numbers defines a range in the perpendicular to the screen outside nothing is displayed. This is useful to visualize the interior of a target, especially in shading view.

Click the **Set scroll limits...** button to adjust the limits for the sliders in the Camera dialogue. The predefined values are good for a medium sized target such as a battle tank, but for a large target such as a ship a scale factor limit of 1 instead of 10 might be more adequate, as well as larger range in the X and Y directions.

9.1.3 Wireframe view

By default the target is displayed in wireframe mode, in which all edges of all components of the target is displayed. Wireframe view is the fastest way to visualize the target model since the amount of calculations needed is much less than in hidden line or shading view (see below).

To select wireframe view, open the pull down menu **Plot options** and then click on **Wireframe**. A checkmark in the menu indicates that this function is active.

9.1.4 Hidden line view

In hidden line mode, the lines hidden behind other lines are removed, and the visible surfaces are filled with the colour of the component the surface belongs to (see below how to select component colours). Hidden line view is much more computer intense than wireframe view, and therefore rotating and translating is slower in hidden line view than in wireframe view.

To select hidden line view, open the pull down menu **Plot options** and then click on **Hidden line**. A checkmark in the menu indicates that this function is active.



9.1.5 Shading view

Shading view is the most advanced way to visualize a target model in AVAL. In this view, edges are not plotted, but the visible surfaces are filled with a colour depending on both the component colour and the reflected light from several light sources. The light sources are customisable, as are the surfaces' colours, transparency and light reflecting properties.

To shading line view, open the pull down menu **Plot options** and then click on **Shading**. A checkmark in the menu indicates that this function is active.

9.1.5.1 Shading colours

To fill surfaces with the components colours instead of grey scale, open the pull down menu **Plot options** and then click on **Enable shading colours**. A checkmark in the menu indicates that this function is active.

9.1.5.2 Transparency

To use the transparency information for each component when displaying the surfaces, open the pull down menu **Plot options** and then click on **Enable transparency**. See chapter 9.1.7 and 9.1.11 on how to set the transparency for components. A checkmark in the menu indicates that this function is active.

9.1.5.3 Material properties

To open the Material properties dialogue box, Figure 35, open the pull down menu **Plot options** and then select **Light model** and then click on **Material properties...**. In this box the light reflecting properties for the target surfaces can be fine-tuned.

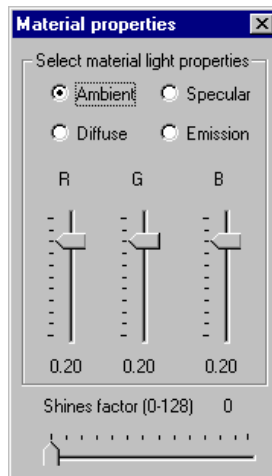

Figure 35: The material properties dialogue box.

Select one of the light types **Ambient**, **Specular**, **Diffuse**, or **Emission** with the radio buttons, and use the sliders to adjust its properties.

9.1.5.4 Light sources

Up to three light sources can be used to illuminate the target. To adjust the properties of the light sources, open the pull down menu **Plot options** and then select **Light model** and then click on **Light source...**, see Figure 36.

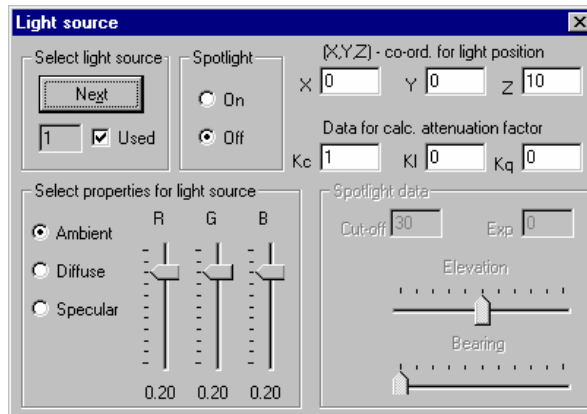

Figure 36: The Light source dialogue box. Up to three different light sources can be configured in this box.

Click the **Next** button to select the light source to adjust, and check the **Used** checkbox to activate this source. Use the different controls to configure the light source.

9.1.5.5 Back face

Normally all visible back faces of surfaces are transparent.

To make surface back faces visible, open the pull down menu **Plot options** and then select **Light model** and then click on **Toggle backface on**. When this function is active, it is marked with a check mark in the menu.

9.1.6 Orthographic projection

By default the target is displayed in perspective view.

To select orthographic projection, open the pull down menu **Plot options** and click on **Orthographic projection**.

9.1.7 Component colours

Open the pull down menu **Plot options** and click on **Set component colours....** Click on one of the radio buttons **Structure**, **Vital**, **ERA** or **LRA**, to select the type of component for which to set the colour.

Use the Red (R), Green (G), and Blue (B) sliders to set the component colour.

Use the Transp. Slider to set the component transparency. Transparency is used only in shading view mode when **Enable transparency** is active.

9.1.8 Background colour

To open the Background colour dialogue, open the pull down menu **Plot options** and select **Light model** and then click on **Background colour....** Use the sliders for Red, Green and Blue colour to set the background colour.

9.1.9 Select target components

To select which components to be included in the plot, open the pull down menu **Plot options** and then click on **Select target components....**

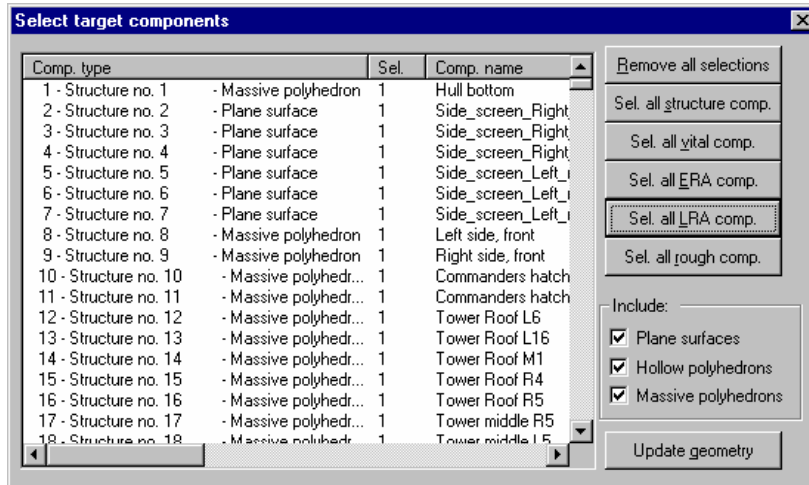

Figure 37: The Select target components dialog box. Select the components to be displayed in the plot.

In the dialog box that appears, Figure 37, all components in the target are listed. By default, all components except rough components are selected to be displayed. To deselect individual components, click on it's number in the list. Notice how the "1" in the Selected column changes to a "0".

To the right of the component list are buttons to select groups of components in one mouse click. The first button deselects all components, the next five buttons selects **all structure**, **vital**, **ERA**, **LRA** and **rough components**, respectively.

Below the selection buttons are three checkboxes to select which geometry type, **plane surface**, **hollow polyhedron** and **massive polyhedron**, to be included in the selection. For example, to select all hollow structure components check hollow polyhedron and uncheck plane surface and massive polyhedron, and click on Select all structure components.

Click on **Update geometry** to transfer the selections made to the target plot.

9.1.10 Select layers

Open the pull down menu **Plot options** and then click on **Select layers...**

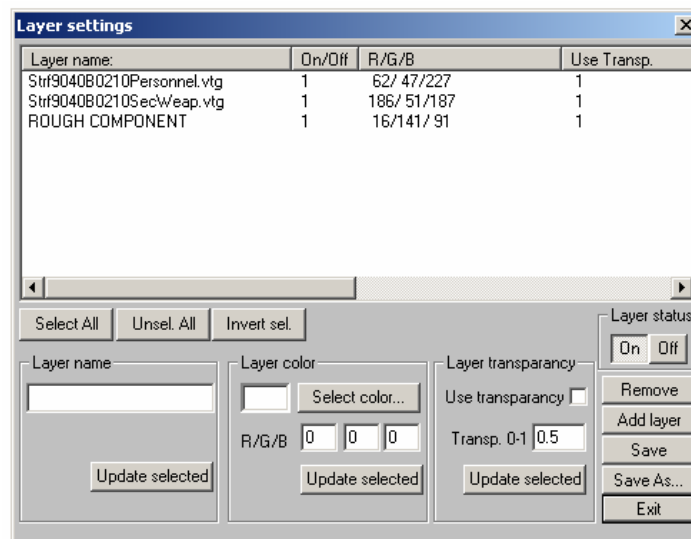

Figure 38: View and edit layer settings.

A dialogue appears, Figure 38, where you can view and edit settings for each layer specified for this target. In this dialogue box you can set layer colours, turn layers off etc.

9.1.11 Color by layer settings

To view component Colours by layer, open the pull down menu **Plot options** and then click on **Colour by layer settings**.

For each component in the target a certain layer can be specified in the component file, right after the component number and name, or when the component is created. If a component doesn't have a specific layer specified, one will be created with same name as the file name where the component is defined. These automatically created layers will have a randomised colour.

All settings made in the dialogue box can be saved into a layer file with the extension **.lay**. If this file is defined in the target file (**.trg**) when the target is read these settings will be restored to the target. Otherwise colours will be randomised as with automatically created layers.

Layer that doesn't have any components connected to it can be removed, if you for example select all layers and click the **Remove** key all layers without components will be removed.

9.1.12 Select transparent components

Open the pull down menu **Plot options** and then click on **Select transparent components....** The following dialogue box is shown, see Figure 39.

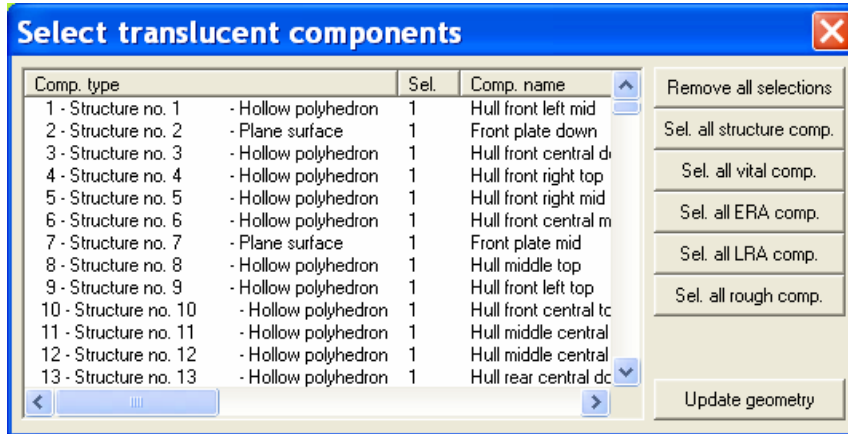

Figure 39: Select translucent components dialogue box.

In this dialogue box, components to be displayed transparent can be selected the same way as in the previous section. Transparency is only used in shading view when enable transparency is active.

9.1.13 Select target volumes

Volumes in the target are composed of hollow structure components in the target.

Open the pull down menu **Plot options** and then click on **Select target volumes...** The Select volumes and compartments dialogue box, Figure 40, is opened.

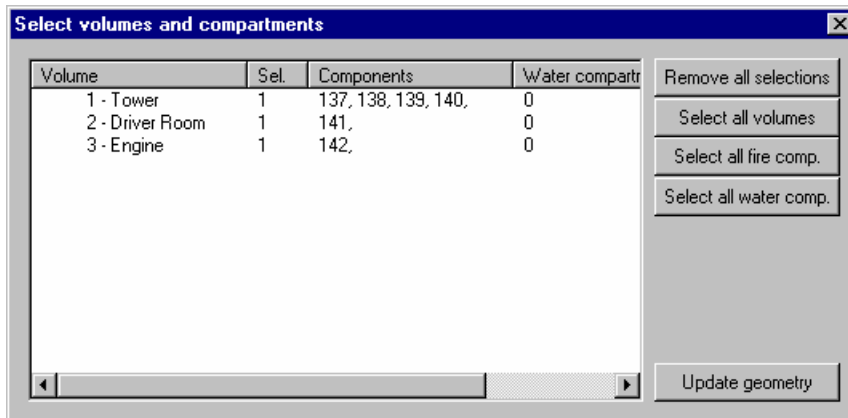

Figure 40: Select volumes and compartments dialogue box.

Select the volumes to display by clicking on its name in the list. Notice how the number in the Selected column changes from “0” to “1”, or from “1” to “0” if it was already selected.

Use the buttons to the right of the list to remove all selections, select all volumes, select all fire compartments or select all water compartments.

Click on the **Update geometry** button to transfer the selections made to the target model plot.

9.1.14 Display components used in fault tree

Open the pull down menu **Plot options** and then click on **Display components used in fault tree...** The Display components used in fault tree... dialogue box, Figure 41, is opened.

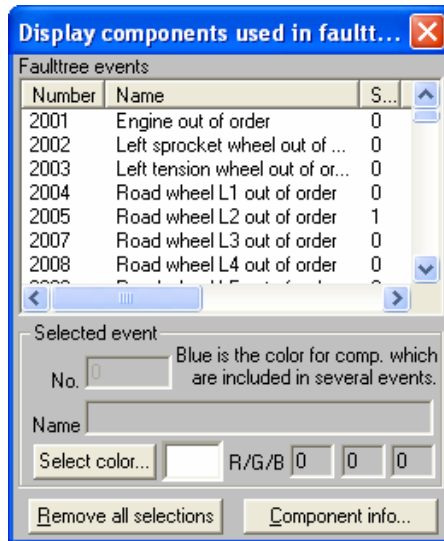

Figure 41: Display components used in faulttree dialog box.

Select the event by clicking on the event number. The plot changes to display all components connected to that event.

When this function is active, it is marked with a check mark in the menu. Click on **Display components used in fault tree...** again to turn this function off.

9.1.15 Splinter generating surfaces

Open the pull down menu **Plot options** and then click on **Plot splinter generating surfaces**. The plot changes to display all splinter generating surfaces in the target model.

When this function is active, it is marked with a check mark in the menu. Click on **Plot splinter generating surfaces** again to turn this function off.

9.1.16 Co-ordinate axes

Open the pull down menu **Plot options** and then click on **Plot co-ordinate axes**. The X, Y and Z co-ordinate axes are plotted in black in the origin of the target.

Click on **Plot co-ordinate axes** again to remove the co-ordinate axes.

9.1.17 Spin geometry

Open the pull down menu **Plot options** and then click on **Spin geometry**. When Spin geometry is selected, the target model is automatically rotated on the screen until **Spin geometry** is selected again.

9.2 Result presentation

In this section you will learn how to study the result of a simulation. We assume that you have performed a simulation so the result files have been generated. The results are studied case by case. If you want you can compare several cases side by side by opening several target view windows and read individual cases into each window.



9.2.1 Read simulation

First of all you need to open the simulation that you would like to study.

Open the pull down menu **Modes** and click on **Single Target...** An empty window (Target No. 1) is opened.

Open the pull down menu **MC simulation** and click on **Read simulation...**

NOTE! It is also possible to show the simulation result by opening a case (**Read case...**). For cases that belong to a multiple case simulation the simulation results are not correct!

Select the type of case you want to open (lethality, *.lsm*, or vulnerability, *.vsm*).

Select the simulation and click **Open**.

NOTE! When AVAL reads a simulation, it automatically reads the target as well. When the simulation is read, you will see the target in the target view window.

9.2.2 Burst points

Here you have the possibility to choose to show the burst points generated by the ammunition.

9.2.2.1 External burst points

Open the pull down menu **MC simulation** and select **Burst points** and then click on **External burst points**. The standard colours are that blue lines are misses while green lines are hits.

9.2.2.2 Internal burst points

Open the pull down menu **MC simulation** and select **Burst points** and then click on **Internal burst points**.

9.2.2.3 Set plot variables

Here you have the possibility to define how plot variables are shown on the screen in terms of size and colour etc.

Open the pull down menu **MC simulation** and select **Burst points** and then click on **Set plot variables...**

9.2.3 Grid

This will plot the grid used in a vulnerability simulation. This will only be shown for vulnerability cases.

Open the pull down menu **MC simulation** and then click on **Grid**.

9.2.4 Vulnerability

Open the pull down menu **MC simulation** and then click on **Vulnerability...**

Select which vulnerability variable to show on the plot. Select the variable and click **Apply**. The target view window will be updated while the Plot vulnerability window will remain open. Below the list of possible plot variables you can see the maximum and minimum values of the selected variable. Close the Plot vulnerability window by clicking

the **X** in the top right corner. You can also select the transparency factor and choose to interpolate colours for a smoother picture.

9.2.5 Lethality

Open the pull down menu **MC simulation** and then click on **Lethality...**

Select which lethality variable to show on the plot. Select the variable and click **Apply**. The target view window will be updated while the Plot lethality window will remain open. Below the list of possible plot variables you can see the maximum and minimum values of the selected variable. Close the Plot lethality window by clicking the **X** in the top right corner. You can also select the symbol size.

9.2.6 Time control

Time control is only active in the single shot simulation mode and is explained in chapter 4.

9.2.7 Remove

To remove all selected plots from the target view window, open the pull down menu **MC simulation** and then click on **Remove plot**.

9.3 Arena test

In the module Single Target there is a capacity to simulate an Arena test with a fragment warhead effect to compare fragment distribution and penetration with real life arena tests or otherwise expected values. The test is performed as a static or dynamic test with existing data for a fragment warhead effect against one of three possible types of arena test target configurations. The result file contains the numbers of fragments penetrating different layers and segments of the target.

9.3.1 Creating an arena test target

The following are the steps taken to simulate an Arena test with a fragment warhead effect. The description assumes that data for a fragment warhead effect already exists. If you need to create data for a new fragment warhead effect, see chapter 10.4.4.6 for details.

Open the pull down menu **Modes** and click on **Single Target...** An empty window (Target No. 1) is opened.

Open the pull down menu **Single simulation** and then click on **Arena test...**, the Arena test dialogue opens, Figure 42.

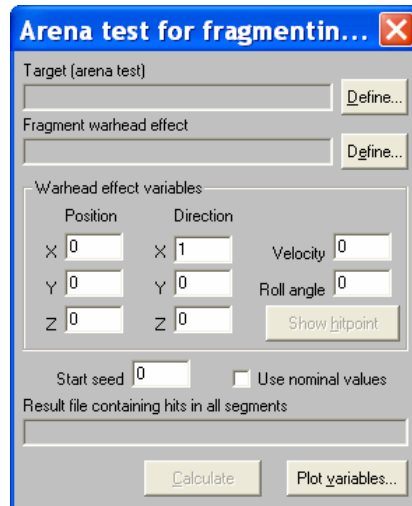

Figure 42: The Arena test dialogue.

Begin by constructing an arena test target. Select **Define...** beside the Target file box, Figure 43.

You are taken to a new dialogue box where you first give the test target a name and then choose one of the three target types **cylindrical**, **polar** or **rectangular**. Clicking the button **OK** takes you to a specific dialogue for each of the three types of arena targets.

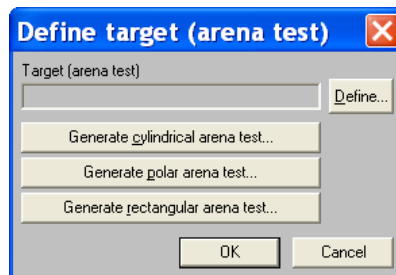

Figure 43: The Define test target dialogue.

9.3.1.1 Generate a cylindrical test target

A cylindrical test target is a test target with plates arranged as a standing cylinder (complete or just a sector) centred on the target z-axis and with target height centred on the x-y-plane. The target may consist of any number of plates around the z-axis but only one plate in height along the z-axis. Each plate can be divided into segments along and around the z-axis. There can be any number of plate layers on different distance, of different thickness and of different material.

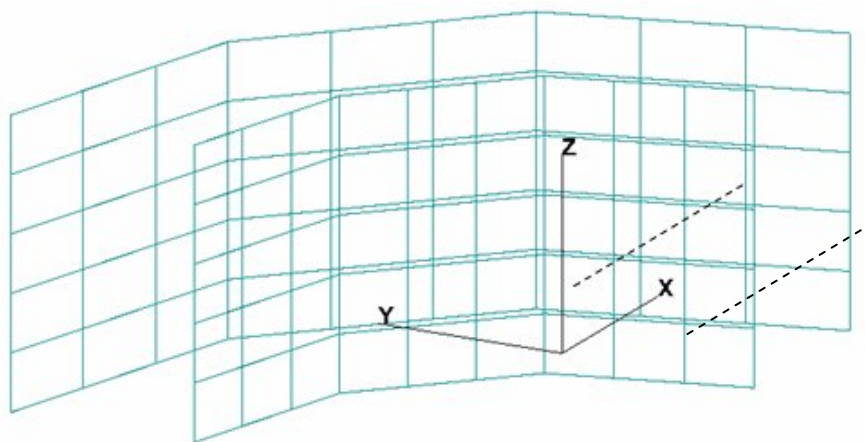

Figure 44: The cylindrical test target.

The target in Figure 44 reflects the input data in Figure 45.

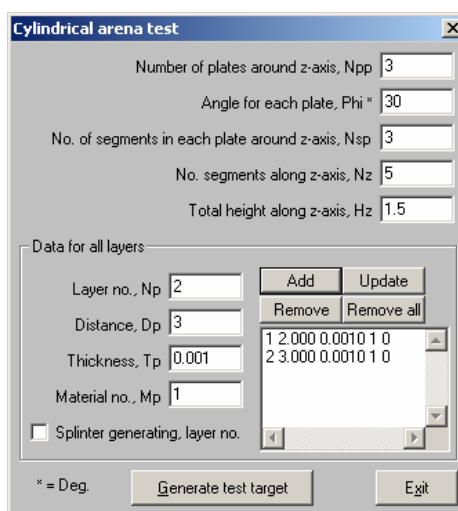

Figure 45: The cylindrical test target dialogue.

Select the number of plates in the target and the angle for each plate.

Enter the number of segments for each plate around and along the z-axis as well as the total target height along the z-axis.

Enter data for each layer in the test target and add the layer by clicking Add. Materials are defined in a specific material file (*.mtl*). If no material data exist when the target is created a default *.mtl* file will be created which is based on default values for mild steel plates. These values may be edited by editing the *.mtl* file. For further information, see the Target Description Manual.

Generate the test target by clicking **Generate test target**. The target data will automatically be saved in the target file (*.trg*) directory. Click **Exit**.

The generated test target will be visible in the target window.

9.3.1.2 Generate a polar test target

A polar test target is a plane target with a cylindrical or elliptical shape. An example of use of this type of arena target is to catch fragments from forward or backwards directed



warheads. The target is located on the target x-axis, perpendicular to and centred on this axis.

The target consists of only one plate at each distance from the z-axis. The plate can be divided into polar segments in the target plane. There can be any number of plate layers on different distance, of different thickness and of different material.

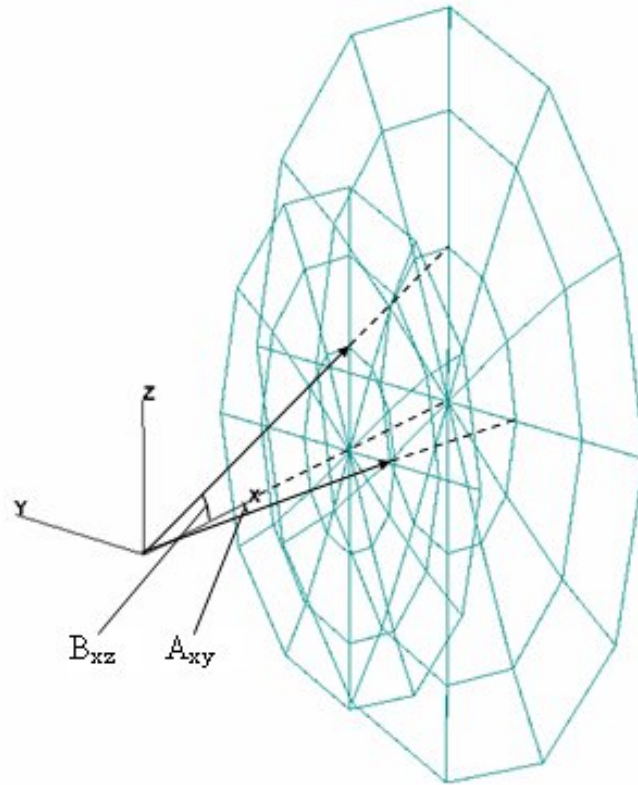

Figure 46: The polar test target.

The target in Figure 46 reflects the input data in Figure 47.

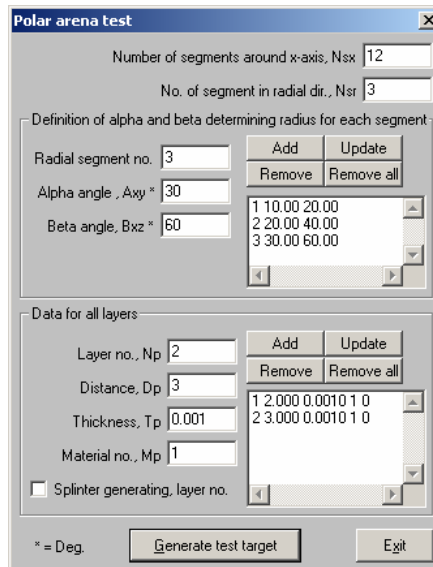

Figure 47: The polar test target dialogue.

Select the number of plate segments in the target. This will determine the number of corners in each plate.

Enter the number of segments in the target radial direction.

Enter data for the alpha and beta angles, which define the half axis. The number of ellipses must equal the number of target radial segments (Nsr).

Enter data for each layer in the test target and add the layer by clicking Add. Materials are defined in a specific material file (*.mtl*). If no material data exist when the target is created a default *.mtl* file will be created which is based on default values for mild steel plates. These values may be edited by editing the *.mtl* file. For further information, see the Target Description Manual.

Generate the test target by clicking **Generate test target**. The target data will automatically be saved in the target file (*.trg*) directory. Click **Exit**.

The generated test target will be visible in the target window.

9.3.1.3 Generate a rectangular target

A rectangular test target is a plane target with a rectangular shape. This type of arena test target is sometimes used directed fragmenting warheads. The target is located on the target x-axis, perpendicular to and centred on this axis.

The target consists of only one plate at each distance from the z-axis. The plate can be divided into rectangular segments in the target plane. There can be any number of plate layers on different distance, of different thickness and of different material.

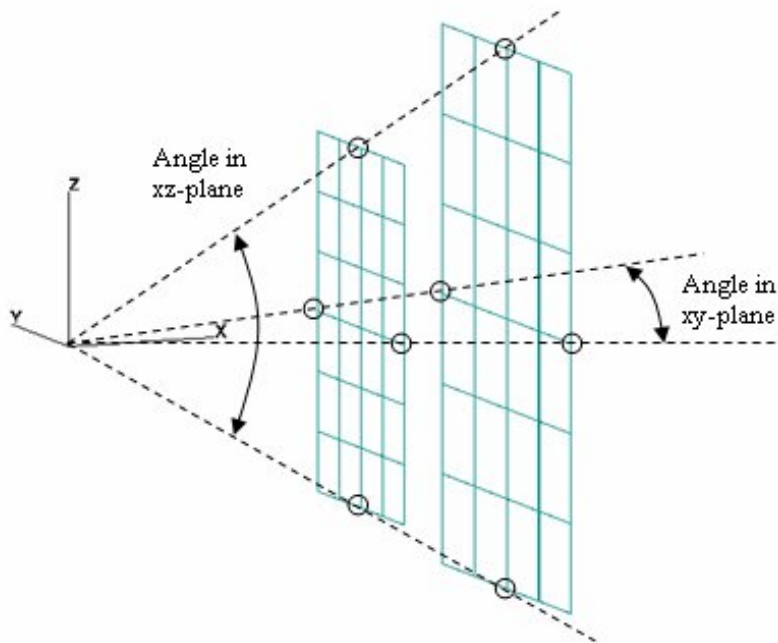

Figure 48: The rectangular test target.

The target in Figure 48 reflects the input data in Figure 49.

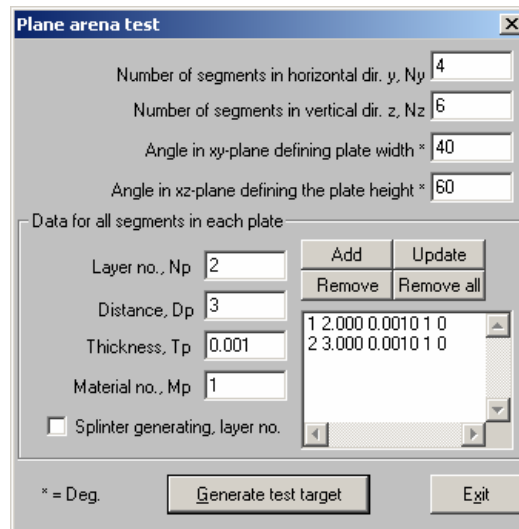

Figure 49: The rectangular test target dialogue.

Select the number of segments in the horizontal and vertical directions.

Enter the angles covering the test target in xy- and xz-planes.

Enter data for each layer in the test target and add the layer by clicking Add. Materials are defined in a specific material file (.mtl). If no material data exist when the target is created a default .mtl file will be created which is based on default values for mild steel plates.

These values may be edited by editing the .mtl file. For further information, see the Target Description Manual.

Generate the test target by clicking **Generate test target**. The target data will automatically be saved in the target file (.trg) directory. Click **Exit**.

The generated test target will be visible in the target window.

9.3.2 Simulating the arena test

Open the **Single simulation / Arena test** dialogue. Describe your arena target as shown above or select a predefined arena target by clicking **Define...** at the Target file line. Select data for the predefined fragment warhead effect to be tested by clicking **Define...** at the fragment warhead effect line and finding the correct file (*.frg*).

Choose position, direction, velocity and roll angle for the warhead effect. **Show hit point** will give a graphical view of the warhead effect 0-point location.

Give a start seed. Use nominal values will tell AVAL to run the simulation without randomness for fragment direction and velocity.

Fire warhead effect by clicking **Calculate**.

Results can be studied graphically and in the result file (*.skv*) created in the fragment warhead effect library. The file is given a name referring to warhead effect and arena target type.

9.3.3 Example of an arena test simulation

Figure 50 shows result for an arena test simulation with a polar arena build up with 10 layers. Each layer has a segmental subdivision witch is 5x10 (5 in radial direction and 10 around the x-axis).

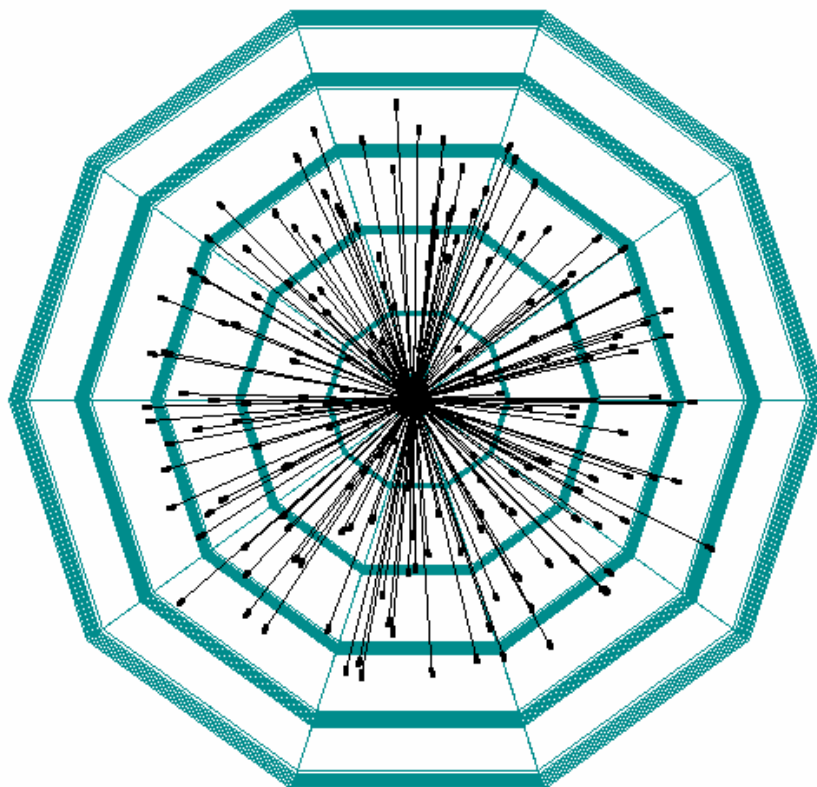

Figure 50: Results for a polar arena test simulation.

The exemple above uses the following data:

- Max number of layers 10 thickness = 10,2,2,2,2,2,2,2,2,2 mm



- Max number of plates 1 1 plate in each layer
- Max number of i segm. 5 $i=1,2,3,4,5$ (radial direction)
- Max number of j segm. 10 $j=1,2,3,4,5,6,7,8,9,10$ (rotational direction)

The output file has the following information:

- information about max number of layers, plates, i-segments, j-segments
- for each layer: Total penetration in mm before hits in each segment, actual layer, actual plate, number of hits in segment with index i and index j

An example of an output file is given in the File format document.

9.4 Create penetration criteria by help of simulations

A tool is available for creating relative protection and a volume based penetration criterion from a complex model to a single component. A paper presented at the ESW-conference in Toulouse 2006 explains the method in detail (Gustafsson and Karlsson; Produce criteria's for vital components by simulations), available on AVAL User group home page.

The evaluation of relative protection and penetration criterion is done by a dialogue box in mode **Single target** under menu **Component** and **Evaluate penetration criterion**. The dialogue is shown in Figure 51.

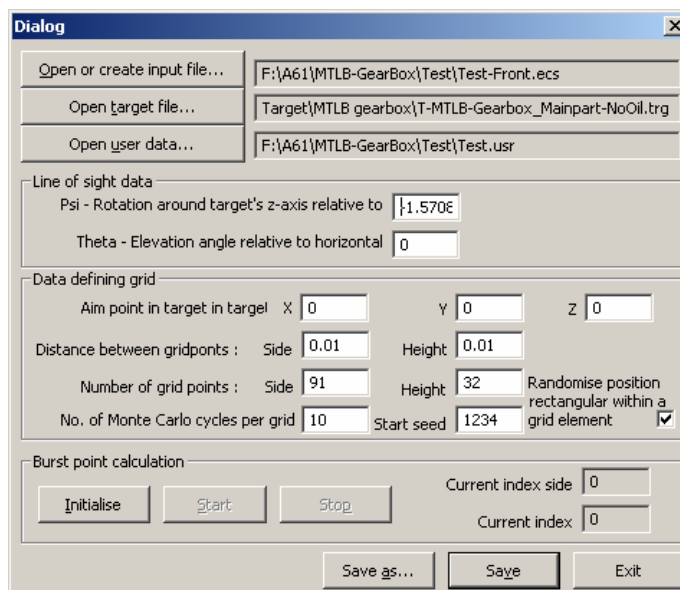

Figure 51: Evaluate penetration criterion dialogue.

All data for the simulation are stored in a file with the extension *.ecs*. A target containing the complex model is of course required and a file containing some user data for evaluating the criterion. All other data are similar to the grid used for vulnerability simulation. Note that the velocity not is defined in the dialogue.

9.4.1 The user input file

An example of the user input file is shown in Figure 52. The first row contains information about the number of components defining the casing. The complex model must contain a

case but the thickness of the case might be zero. On the following rows are the type and identification data for components building up the casing defined.

Also a fault tree must be defined for the complex model. In the user input file are the events causing failure of the complex model also defined. In this example only one event is used.

In the evaluation process several crater diameters might be investigated during a simulation. In this case were 20 crater diameters from one to 20 mm simulated for single fragment. On the last row is the reference material for mild steel defined (the material file for the complex model).

```

2          ! No. of components defining outer limit for investigated part
4      3245 ! Comp. type and ident 1 (type 1=Era, 2=Lra, 3=StructurePart, 4=VitalPart)
4      3268 ! Comp. type and ident 2
1          ! No. of events used for calc.
20001     ! Event 1
0.001 0.020 20 ! Min and max crater diameter, number of values including min and max
10 0      ! Evaluation time
22        ! Penetrator type ( KE=12, SC=16, EFP=18, Frag=22 )
1          ! Reference material for mild steel
    
```

Figure 52: Example of User Input File.

9.4.2 Simulations

In the input data crater diameters are defined instead of projectile diameter. The total crater volume made in vital parts are recorded for every penetrating object during the path through the complex model. Even the relative protection expressed in mild steel for each path is stored. All this data are stored in a result file named *Test-Front-Eval.skv*.

When all paths are simulated an evaluation is done and printed in the result file named *Test-Front-EvalResult.skv*.

9.5 Generation and modification of target data

In the program there is a possibility to create and edit targets for AVAL. These functions are not intended to replace AVALCAD, rather to be used to create simple test targets or to edit components in existing targets. To create real targets it is STRONGLY recommended to use AVALCAD.

In this section you will learn where to go if you want to create and edit targets inside AVAL. For creation and editing of components this will be quite schematic. For detailed explanations of how components and targets are built up we recommend going to the Target Description Manual.

9.5.1 Target

Open the pull down menu **Modes** and click on **Single Target...** An empty window (Target No. 1) is opened.

The pull down menu **Target** is where existing targets can be opened (**Read target...**), a blank target file be created (**Create target...**) and created or edited target files be saved (**Save target...**).

For the following sections it is assumed that a target is read.



9.5.2 New component

The pull down menu **New component** is where you can create new components and add it to your target.

Open the pull down menu **Component** and then click on **New component....**

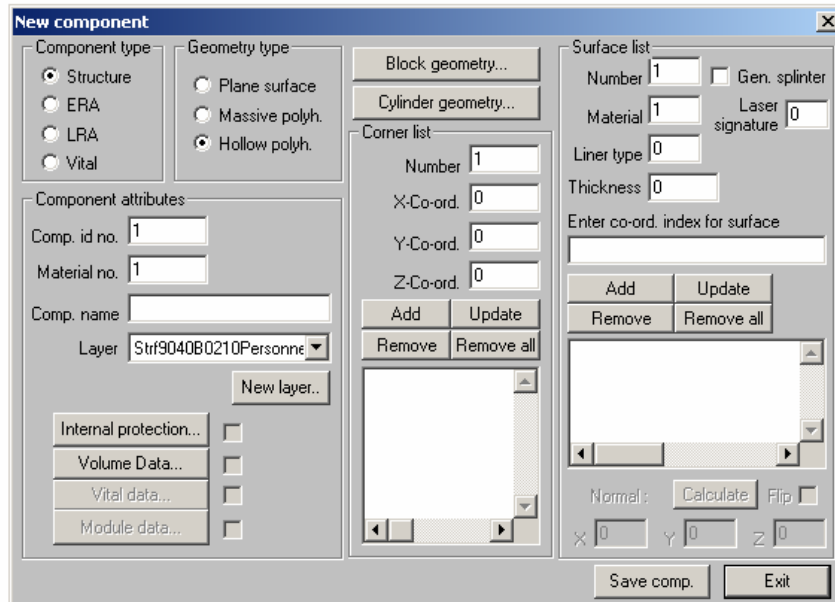

Figure 53: The New component dialogue box.

By selecting the type of component you want to create (**Structure**, **ERA**, **LRA** or **Vital**), see Figure 53, different input blocks will be active in the dialogue box.

Select the geometry type. For ERA and LRA the only choice is **hollow polyhedron**.

Select a Component identity number and the Material number corresponding to the material defined in the material definition file (*.mtl* file). Give the component a name and select an existing layer or crate a new layer connected to the component.

Define the geometry. This can be done in more than one way. The easiest way is to select a pre-defined geometry, either **Block geometry...** or **Cylinder geometry...** and enter the required data. Alternatively you can define the geometry by specifying each corner and surface in the Corner list and Surface list blocks. Plate thickness may be edited for each surface.

For Hollow polyhedrons you need to enter data for **Internal protection** in the Internal protection dialogue, Figure 54. The internal protection is given as a table with protection and corresponding probability. The probability values must start with 0 and end with 1.0.

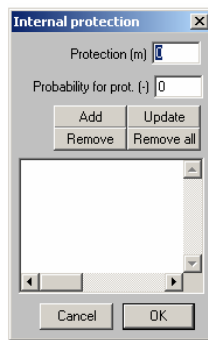

Figure 54: The Internal protection dialogue box.

For ERA and LRA components you need to define **Module data**. In the Module data dialogue, Figure 55, you define which one of the surfaces that are the inside and the outside respectively and finally (only for ERA) two radii and one exponent specifying how the probability to destroy the uninitiated module varies with the distance from the centre of an initiated module to the centre of the adjacent one.

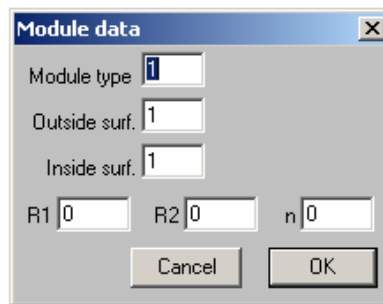

Figure 55: The Module data dialogue box

For Vital components you need to define **Vital data** in the Vital data dialogue box, Figure 56. In the dialogue you need to define, for each phenomenon that can cause damage to the component, a Damage criteria that will define what type of damage the component will suffer. You can also select the type of Vital component from a list with pre-defined types that need some additional input.

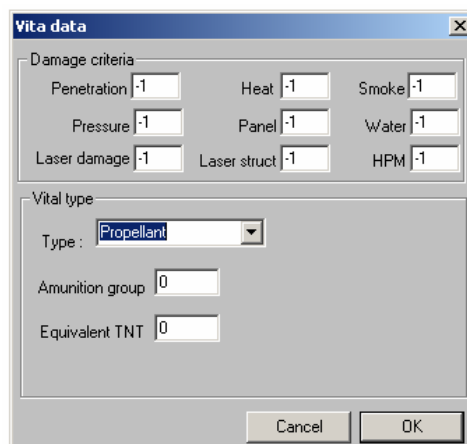

Figure 56: The Vital data dialogue box.

Save the component and enter the volume data. (Because vitals connected to volumes refer to the volume by memory pointers the vital must be saved before volume data is set).



Save and exit.

9.5.3 Copy component

Open the pull down menu **Component** and then click on **Copy component...** In the dialogue box, Figure 57, you will be presented with two main areas.

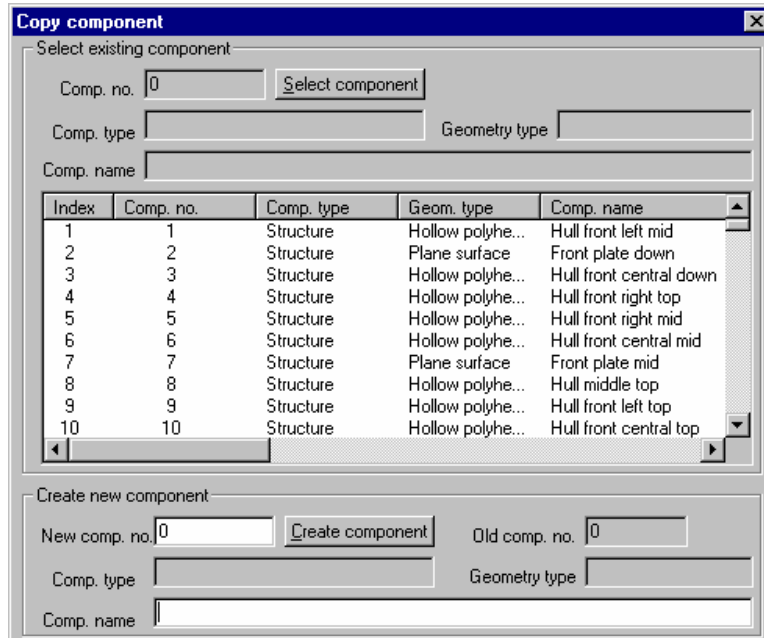

Figure 57: The Copy component dialogue box.

In the top one you select an existing component, either from the list or with the mouse selection method (explained below). In the bottom block **Create new component** you give the copy of the selected component a new component number and possibly a new component name.

Click **Create component** to create the copy of the selected component with a new number.

Repeat to create copies of other components if necessary.

9.5.4 Delete component

Open the pull down menu **Component** and then click on **Delete component...**

Select a component to be deleted, either from the list or with the mouse selection method.

Click **Delete** component.

9.5.5 Enable mouse selection

With mouse selection enabled you can select components by clicking on them in the target view window.

Open the pull down menu **Component** and then click on **Enable mouse selection**.

9.5.6 Select from list

You can select individual components in the target. In the target view window the selection will be shown.

Open the pull down menu **Component** and then click on **Select from list....**

9.5.7 Modify attributes

Here you can modify attributes of existing components. The attributes are the same as in the New component... dialogue box. It is important to do this in the correct order.

Open the pull down menu **Component** and then click on **Modify attributes ...**

Then select the component you would like to edit. The component can be selected either with the mouse selection method or the Select from list method.

Modify the attribute and save the edited component.

9.5.8 Modify co-ordinates

Here you will learn how to edit the geometry of existing components.

9.5.8.1 Co-ordinate list

Open the pull down menu **Component** and select **Modify co-ordinates** and then click on **Co-ordinate list ...**

Select a component (with the mouse or from the list) and you have the possibility to edit the geometry of the component.

Save the component.

9.5.8.2 Translate

Open the pull down menu **Component** and select **Modify co-ordinates** and then click on **Translate....**



Figure 58: The Translate dialogue box.

Select a component (with the mouse or from the list).

Enter translations, see Figure 58, to move the component to a new location.

Save the component.



9.5.8.3 Rotate

Open the pull down menu **Component** and select **Modify co-ordinates** and then click on **Rotate....**

Select a component (with the mouse or from the list).

Define the axis to rotate the component around.

Enter the rotation angle in degrees.

Save the component.

9.5.8.4 Mirror

Open the pull down menu **Component** and select **Modify co-ordinates** and then click on **Mirror....**

Select a component (with the mouse or from the list).

Define the mirror plane.

Save the component.

9.6 Test geometry

In the pull down menu **Test geometry** you get some choices for testing the geometry of a target. You will use these only during a target creation process or when editing an existing target. Once a target is finished and has passed these tests there is no need to test it again.

The following submenus are available under Test geometry:

- Calculate intersections
- Plot intersections
- Intersection options
- Check if all corner points are in a plane
- Check thickness for all plane surfaces
- Check internal protection

9.6.1 Calculate intersections

Intersections are calculated and listed in an output file for selected component options showed in the dialogue in Figure 59. Min intersection depth in output file is a value that defines the smallest intersection listed in output file.

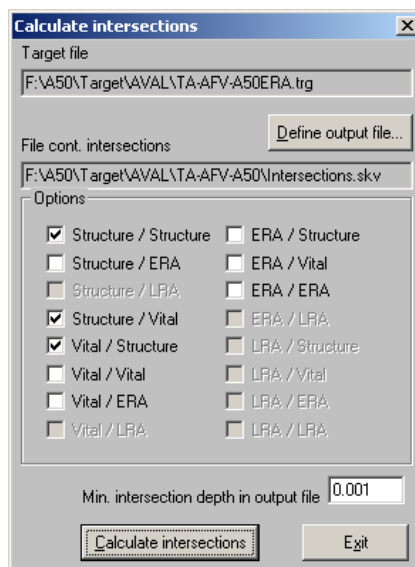

Figure 59: The Calculate intersections dialogue box.

The output file contains the information shown in Table 5.

Table 5: Calculate intersection output file information.

| Comp. no | Component number tested for intersection |
|---------------------|--|
| Comp type | Component type (1,2,3,4) |
| Int. by comp no. | Intersected by component number |
| Int. by comp type | Intersected by component type |
| Intersection length | Depth for intersection |
| Point 1 x-comp | x-component for intersection point no. 1 |
| Point 1 y-comp | y-component for intersection point no. 1 |
| Point 1 z-comp | z-component for intersection point no. 1 |
| Point 2 x-comp | x-component for intersection point no. 2 |
| Point 2 y-comp | y-component for intersection point no. 2 |
| Point 2 z-comp | z-component for intersection point no. 2 |

An example of an output file is given in the File format document.

9.6.2 Plot intersections

Intersection are displayed and highlighted with a specific colour, see example in Figure 60.

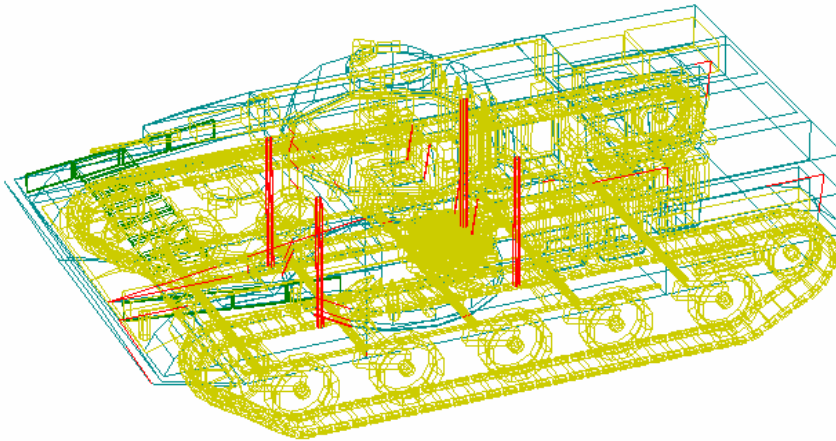

Figure 60: Example of plotted intersections.

9.6.3 Intersection options

In this dialogue, Figure 61, colour and components selected for displaying intersections.

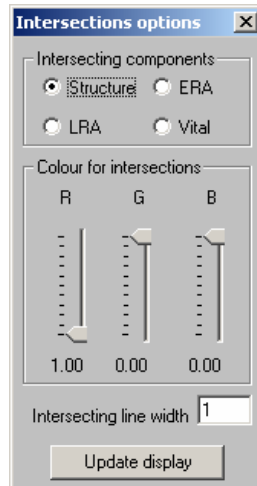

Figure 61: The Intersections options dialogue box.

9.6.4 Check if all corner points are in a plane

In this dialogue, see Figure 62, errors are calculated and listed in an output file for all component surfaces. In AVAL several points than three can be used for describing a plane surface for a component. Min errors in output file are the tolerances used for considering a surface there all points are in a plane.

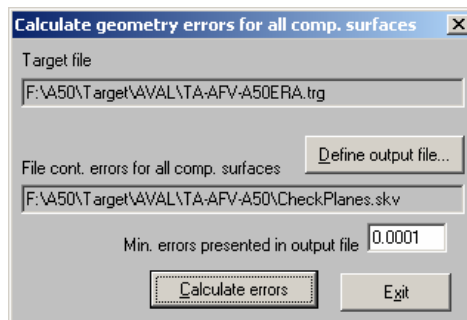

Figure 62: The Calculate geometry errors for all comp. surfaces dialogue box.

The output file contains the information shown in Table 6

Table 6: Calculate geometry errors for all comp. surfaces output information.

| Comp. no | Tested component number |
|--------------|------------------------------|
| Comp type | Component type (1,2,3,4) |
| Surface no. | Surface number |
| Point no. | Point number |
| Point x-comp | x-component for point number |
| Point y-comp | y-component for point number |
| Point z-comp | z-component for point number |
| Error | Error for this point |

An example of an output file is given in the File format document.

9.6.5 Check thickness for all plane surfaces

The program test if any plane surface has a thickness less or equal to zero. If this is true this component is displayed in s message box.

9.6.6 Check internal protection

The internal protection is checked for all vital components which has volume dependent penetration criteria. If internal protection is zero these components are listed in a message box, see Figure 63.

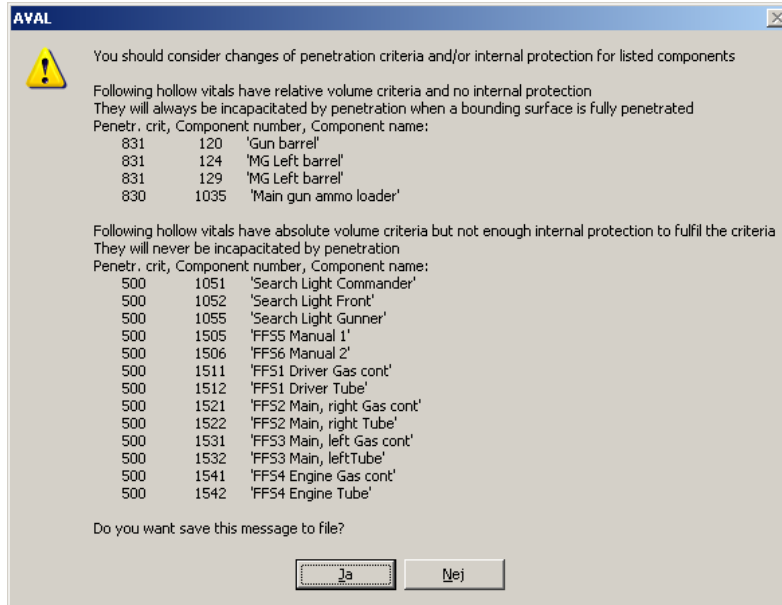

Figure 63: Internal protection message box. (Ja = Yes, Nej = No)

This result can also be listed into an output text file.

If the number of components is too big to fit in the dialogue box above, it will not be shown on the screen. However, the file can still be saved.

10 Generating weapon data

In AVAL, all types of conventional ammunition are described in a generic system called a Warhead carrier. This physically corresponds to what is flying in the air, i.e. a projectile or a missile. A warhead carrier can consist of one Fuze and a number of Warheads and the fuze can consist of a number of Sensors and triggering conditions. The warhead can consist of several Warhead effects. In this chapter you will learn how to construct your own ammunition to be used for AVAL simulations. Generation of ammunition data is performed in the pull down menu **Warhead carrier** and its sub menus. In chapter 12.1 all menu choices for the Warhead carrier can be seen.

EM weapons are described differently due to its much different nature of effect and absence of a fuze.

10.1 Sensors

Sensors are used to sense when a target is within reach of a warhead. In AVAL there are several sensors types available for use.

10.2 Height (.hse)

Height sensors are used to detonate a warhead carrier on a pre-selected height.

Steps in definition of a height sensor:

Open the pull down menu **Warhead carrier** and select **Sensors** and then click on **Height...**

Click on the **Open file...** key. Select an existing file or define a new one.

The following data defines a height sensor:

- Function probability – a number between 0 and 1.
- Mean burst height – defined in meters.
- Standard deviation burst height – variation in burst height.

10.2.1 Impact (.imp)

10.2.1.1 Basic data

Impact sensors are used to trigger a warhead carrier on impact of the target. For some warhead carriers (e.g. a penetrating anti-ship missile that is supposed to detonate inside the targeted ship) there may be of interest to set data for internal burst points.

Steps in defining an impact sensor:

Open the pull down menu **Warhead carrier** and select **Sensors** and then click on **Impact...**

Click on the **Open file...** key. Select an existing file or define a new one.

The following data defines an impact sensor:

- Function probability – a number between 0 and 1, where 1 is 100% probability for triggering.



- Min angle for function – Minimum angle between sensor and surface that give a trig signal. Angle given in radians.
- Co-ordinates defining points for sensor – one or more points that make up the sensor. Give the appropriate co-ordinates in the warhead carrier co-ordinate system and click **Add** to add the point. At least one point needs to be defined.

10.2.1.2 Data for internal burst point generation (.int)

Defining these data is optional. Using this option will couple the impact sensor to a specific warhead/projectile.

- Time delay until burst, dt – given in seconds.
- Projectile mass, m – in kilograms.
- Projectile diameter, d – in meters.
- Half nose cone angle, theta – in radians.
- Fitness factor, gamma – the default value is 1.
- Shock initiation function – triggers the warhead if a velocity change (decrease) greater than the limiting value occurs.
- Projectile penetration, G(v) – pairs of penetration vs. velocity values. AVAL will make a linear interpolation between the points. Typing numbers and clicking Add will add points to the table and AVAL will automatically sort the data pairs in increasing velocity order.

10.2.2 Laser (.las)

The laser sensor will be triggered if the laser beam senses an object (the target).

Steps in defining a laser sensor:

Open the pull down menu **Warhead carrier** and select **Sensors** and then click on **Laser...**

Click on the **Open file...** key. Select an existing file or define a new one.

The following data defines a laser sensor:

- Function probability – a number between 0 and 1, where 1 is 100% probability for triggering.
- Sample frequency – the number of samples per second
- Geometry and trig probability per sample in target – two points in space and the probability to detect the target in each of them.

10.2.3 Proximity (.pro)

The proximity sensor will trigger if a target is within its sensor lobe.

Steps in defining a proximity sensor:

Open the pull down menu **Warhead carrier** and select **Sensors** and then click on **Proximity...**

Click on the **Open file...** key. Select an existing file or define a new one.

The following data defines a proximity sensor:

- Function probability – a number between 0 and 1, where 1 is 100% probability for triggering.
- Min grid density – this should be small enough to be able to detect the smallest parts of the target.

- Data for the lobe – Geometry of the sensor lobe. Burst probability per meter is the probability to initiate the warhead per meter swept by the sensor. Add one or more points by typing numbers and clicking **Add**.

10.2.4 Time (.tim)

The time sensor will trigger after a predetermined time of flight.

Steps in defining a proximity sensor:

Open the pull down menu **Warhead carrier** and select **Sensors** and then click on **Time....**

Click on the **Open file...** key. Select an existing file or define a new one.

The following data defines a time sensor:

- Function probability – a number between 0 and 1.
- Mean value for time delay – defined in seconds
- Standard deviation value for time delay – variation in time delay.

10.2.5 Active pulsed laser (.apl)

The active pulsed laser will search for a target with pulsed laser beams. It is constructed of three parts, an emitter, a receiver and a signal-processing unit. If you want to use this sensor in a simulation the target to be used must have signature data specified for each outer surface and a file included in the file package specifying the ground properties.

Steps in defining a proximity sensor:

Open the pull down menu **Warhead carrier** and select **Sensors** and then click on **Active pulsed laser....**

Click on the **Open file...** key. Select an existing file or define a new one.

The sensor definition needs the following basic data in addition to emitter, receiver and signal processing unit data as described below:

- Enter a value for Calculation range in m. This will limit the analysis to situations where the distance from the sensor to the target is smaller than the given value and speed up the calculation.
- Enter a value for Meteorological visibility in m (see the Reference manual for definition).

10.2.5.1 Emitter

One or more emitter lobes and laser data define the emitter. Each laser emits its radiation in one lobe defined by one or several rays specified by two angles, alpha and beta, in the warhead carrier co-ordinate system as well as the optical power the ray is carrying.

Lasers are coupled to the emitter lobes in the second box in the emitter dialogue box.

Lasers are defined by the position and direction in the sensor. You also need to specify the laser pulse shape (pairs of time and relative pulse power) and a schedule specifying the time sequence for when the laser is lit.

10.2.5.2 Receiver

The receiver consists of one or several lenses, each connected to one field of view, one or several detectors and an amplifier. The position, direction, aperture, field of view range and transmission for each lens shall be entered as well as a polygon specifying the cross section of the field of view.



Then you need to specify data for the detectors, connect each detector to field(s) of view and evaluation block(s) and give data (sub sample factor, number of data bits and reference level in A/D converter) for each evaluation block.

10.2.5.3 Signal processing unit

The signal processing unit uses six criteria to decide if a real target is detected or not and you have to specify acceptance conditions for these criteria (stand-off, edge position, edge height, surface tilt, form factor and object height). See the Reference manual for more description.

10.2.6 Magnetic (.mag)

The magnetic sensor will trigger on disturbances in the magnetic field from a vehicle. Examples of use are in torpedoes and mines. When this sensor is to be used the target must have a certain file included in the description, specifying empirical signal data in a 3-dimensional space matrix around the target.

Steps in defining a magnetic sensor:

Open the pull down menu **Warhead carrier** and select **Sensors** and then click on **Magnetic...**

Click on the **Open file...** key. Select an existing file or define a new one.

The following data defines a magnetic sensor:

- Low pass frequency – Specify a frequency above which a signal will be disregarded.
- Noise RMS-value – Specify the noise level.
- Sub sample factor – Specify a sub sample factor
- Threshold value for detection - Specify a signal level as a criterion for detection.

10.2.7 Empirical IR (.eir)

The empirical IR sensor will use associated input files to determine;

- if there is a false trig before the first target or between targets
- if the sensor will trig on the target
- where on the target the trig point is situated

Open the pull down menu **Warhead carrier** and select **Sensors** and then click on **Empirical IR...**

Click on the **Open file...** key. Select an existing file or define a new one e.

The following data is required in addition to the associated input files:

- Function probability – a number between 0 and 1, where 1 is 100% probability for triggering.
- Rotation velocity – the warhead/sensor rotation rad/s.
- Warhead vertical angle from IR – the fixed vertical offset of the warhead rel. the IR sensor.
- Warhead horizontal angle from IR – the fixed horizontal offset of the warhead rel. the IR sensor.
- Warhead offset –the warhead horizontal offset, in radians, due to rotation velocity.
- View angle –the IR view angle from the rotation axis angle.
- Rotation axis angle –the angle of the rotation axis relative a vertical axis.
- Oscillation amplitude – the amplitude of the IR axis oscillation.

- Oscillation frequency - the frequency of the IR axis oscillation.
- Sampling frequency –the IR sensor sampling frequency.
- Delay samples –number of samples from trig to firing the warhead, decision time.
- Start altitude –the height where the IR sensor starts.
- File path false alarm –path to file containing the false alarm risk in various altitudes.
- Target specific data – data for sensor sensitivity on specific targets.
- Associated target –a list of AVAL targets this sensor is able to handle. Each associated to data files by the search path to the **.trg**-file. For each target in list is defined:
 - Transformation data –how to translate, rotate and scale detection points from the detection points file to the AVAL target.
 - A detection point file with possible detection points in various altitudes and attitudes.
 - A trig probability file with trig probability in various altitudes and attitudes.

10.3 Fuze system (.fze)

Open the pull down menu **Warhead carrier** and then click on **Fuze system...**

Click on the **Open file...** key. Select an existing file or define a new one. It is optional to give it a descriptive title.

- Define sensors – the sensor(s) to be used in the fuze system are added by clicking **Add sensor...**and selecting the appropriate sensor file. Unwanted sensors can be removed by selecting the number of the unwanted sensor in the sensor list and clicking **Remove sensor**.
- Define trig conditions – Type the number of the primary sensor, specify the mean delay time and the standard deviation and which secondary sensors are triggered by the primary sensor and click **Add condition**.

Save the file when you are finished.

10.4 Warhead effect

Warhead effects are the effects that build up a warhead. An example can be a shaped charge with fragments and blast effects. This warhead would consist of three warhead effects: shaped charge, fragmenting charge and high explosive charge.

10.4.1 Shaped charge (.sce)

Select the shaped charge warhead effect from the pull down menu.

Open the pull down menu Warhead carrier and select **Warhead effect** and then click on **Shaped charge...**

Click on the **Open file...** key. Select an existing file or define a new one. It is optional to give it a descriptive title.

Select the different categories and give the necessary input as explained below.

Beside every category button there is a checkbox to help you keep track of which data have been completed. In order to be able to use the shaped charge warhead effect only **Geometry...** and **Jet penetration and crater diameter...** data need to be supplied. This will however only give penetration data and no splinters will be generated. It is therefore



recommended that **Jet splinter generation...** and **Secondary splinter generation...** data are supplied to give a realistic effect in the target. As the names suggest, **Target specific ERA data...** and **Target specific LRA data...** are given for a certain combination of warhead effect and target. The ERA/LRA-module data are contained in the target description.

10.4.1.1 Geometry

- Charge calibre, C – in meters.
- Jet tip velocity, Vjet – in meters per second.
- Jet penetration and diameter
- Constant scaling parameter for penetration and crater diameter, Cc – this value (in charge calibre) will be added to or subtracted from the basic penetration value.
- Linear scaling parameter for penetration and crater diameter, Cl– the basic penetration value will be multiplied with this constant.
- Critical impact angle for penetration defined by plate thickness, AlphaCrit(t) – The minimum angle between the jet and the target surface, to achieve any penetration, given as a table with plate thickness and critical angle. During simulation the critical angle is calculated from the table.
- Number of stand-off curves to be randomised among, Nc –based on the given stand-off curve, the program will randomly “draw” this number of stand-off curves to be randomly selected during the simulation.

10.4.1.2 Penetration

- G – input points on the stand-off curve for the shaped charge. Each point on the curve consists of the stand-off, penetration and standard deviation of the penetration. All numbers in charge calibre. Type numbers and add them to the curve by clicking **Add**.
- Crater diameter – crater diameter is given in the same way as the stand-off curve.

10.4.1.3 Jet splinter generation

There are several parameters involved in the process of describing jet splinter generation. They are described in separate “blocks” in the dialogue box. This formulation is used in several splinter generation description and will be treated in detail in this section and only schematically (with pointers to this section) in other sections of this document.

- Used, **On** or **Off** – the simulation can be run with or without jet splinter generation. It is turned on or off with this choice. If no jet splinter generation data is defined, the simulation can only be run with the **Off** condition chosen.
- Jet splinter cone angle, Beta – this is the description of the opening angle of the cone where jet splinters fall. It contains the Parameter X (used in several equations in the AVAL code), which is the already used relative penetration capability of the jet. It always varies from 0 to 1. The jet splinter cone angles are dependent upon the parameter X and the impact angle. Impact angles must vary between 0 and 1.5708 radians. Any number of impact angles and parameter X can be used. In the table below three values of parameter X and two values of the impact angle have been specified. Impact angles are typed separated by blank spaces. For each chosen value of the parameter X, the cone opening angles (the same number as the number of impact angles) are typed separated by blank spaces and added to the table by clicking **Add**, see example in Table 7.

Table 7: Parameter X and impact angles.

| Parameter X | Impact angles |
|-------------|---------------|
|-------------|---------------|

| | | |
|-----|-----|--------|
| | 0 | 1.5708 |
| 0 | 0.1 | 0.05 |
| 0.5 | 0.2 | 0.1 |
| 1 | 0.3 | 0.15 |

- Splinter distribution – this is to describe the distribution of splinters within the splinter cone. The radial direction for a splinter is randomised from either a rectangular distribution or a user defined distribution. Marking the corresponding checkbox chooses the rectangular distribution. If a user defined distribution is preferable it is defined by pairs of values of xArg (0 to 1 on the x-axis) and F(xArg) (distribution value on the y-axis). Input the data in the standardised AVAL manner. The circular distribution of splinters is always a rectangular distribution between $0-2\pi$.
- Number of jet splinters, Ns – this is defined as a function of the parameter X. For each value of X a minimum and a maximum number of splinters are defined. AVAL will randomise the actual number of splinters formed in the perforation of a splinter-generating surface (based on a rectangular distribution between minimum and maximum number of splinters) during a simulation.
- Penetration capability, Gs – the minimum and maximum penetration capability of the formed jet splinters are given as a function of the parameter X. AVAL will randomise the actual penetration capability (based on a rectangular distribution between minimum and maximum penetration capability) during a simulation.

10.4.1.4 Secondary splinter generation

Secondary splinter generation is defined in the same way as jet splinter generation with a few additions.

- Splinter cone geometry – is defined with the addition of the gamma angle. The gamma angle is the angle between the jet and the secondary splinter cone axis of symmetry.
- Splinter distribution – exactly as jet splinter generation.
- Number of splinters – since this is now a function of the impact angle as well as the parameter X, this is input as lists in the same way as the splinter cone geometry.
- Penetration capability, Gsek – input as lists in the same way as Number of splinters.
- Target specific ERA data (*.dat*)
- If the penetration capability is to be reduced by Explosive Reactive Armour (ERA) it needs to be coupled to a specific target. The ERA-modules are defined in the target description and need to be defined before the projectile data is defined.
- **Open target file (.trg)...** opens the target file that has the ERA-modules defined. In the list to the right the different ERA-module types defined in the target can be seen.
- Click on the **Open file...** key. Select the first ERA module type in the list. The number of the module type will be shown in the block Data for current ERA module type.
- In the File containing ERA data the interaction between ERA-module and jet is described. If no interaction file is defined you need to create a new file by clicking Create file... and giving a new file name.
- The two radii R1 and R2 are used to describe the probability to initiate ERA-modules close to the one being hit and initiated. The exponent n describes the variation of the initiation probability between R1 and R2 and must be larger than 0.



- The block Penetration reduction, R_g defines the penetration reduction of the jet caused by the initiation of the ERA-module. The Distance def. edge area, D is used to differentiate between hits in the centre of the module and hits closer to the edge and the different penetration reductions that are the results in the two cases. You then need to input reduction values for different impact angles and stand off. Reduction values are defined as the relative amount of penetration capability that the module consumes and should therefore be a number between 0 and 1.

The block Penetration correction for tandem main charge, R_{mg} needs to be defined even if no tandem charge is used. The correction describes the influence on the main charge from an ERA-module initiated by another shaped charge. NOTE! The impact angle is in this case defined as the angle between the jet and the surface normal vector. You need to give two impact angles, 1.5708 and 0 radians are suggested. Thereafter, for the distance 0 meters between the module and the main charge, input two penetration correction values (separated by a blank space) corresponding to the two impact angles. At least one more pair of correction values need to be input for another distance between initiated ERA-module and the main charge. Save the data by clicking **Save data...**

Repeat the above steps for each ERA-module type and remember to save the data for each module type in individual files.

10.4.1.5 Target specific LRA data (**.dat**)

Penetration reduction from low reactive armour (LRA) is defined in the same way as for ERA-modules. The only difference is that there is no need to define any tandem charge correction, and that there should not be any values for R_1 , R_2 and n entered.

10.4.2 Kinetic energy projectile (**.kep**)

The kinetic energy projectile warhead effect is used to model all kind of KE projectiles.

Open the pull down menu **Warhead carrier** and select **Warhead effect** and then click on **Kinetic energy projectile...**

Click on the **Open file...** key. Select an existing file or define a new one. It is optional to give it a descriptive title.

Select the different categories and give the necessary input as explained below. Beside every category button there is a checkbox to help you keep track of which data have been completed.

10.4.2.1 Penetration

Basic data for the KE projectile are Total projectile mass, m_0 (in kg, the mass of the projectile when it hits the target) and Critical impact angle for penetration defined by plate thickness, $\alpha_{crit}(t)$ – The minimum angle between the projectile and the target surface, to achieve any penetration, given as a table with plate thickness and critical angle. During simulation the critical angle is calculated from the table.

Penetration capability is given as pairs of penetration, G , at impact velocity, V_i (m/s). Type in numbers and add them to the table by clicking **Add**. Begin with values for impact velocity 0 m/s (which should correspond to 0 m penetration capability).

The Penetration correction impact angle, K_{α} block is used to correct the penetration capability for different impact angles. The Correction factor, K_{α} , is multiplied with the basic penetration capability. Impact angles must vary from 0 to 1.5708 radians.

The Penetration correction yaw angle, K_{δ} is the correction for differences between the mass centre's movement path and the longitudinal axis of the KE projectile. It is assumed

that the correction is equal for positive and negative yaw. Impact angles must be between 0 to 1.5708 radians.

10.4.2.2 Penetration reduction and crater diameter

- Velocity correction, K_v is the reduction of projectile velocity as penetration capability is consumed. It is entered as pairs of Parameter, X (used penetration capability) and correction factor, K_v .
- Mass correction, K_m is the reduction in projectile mass as penetration capability is consumed. It is entered as pairs of Parameter, X (used penetration capability) and correction factor, K_m .
- Crater diameter, D_c (meters) is given as a function of impact velocity, V_i . Begin with impact velocity 0 m/s.
- Rotation velocity disturbances, W_o are the disturbances induced in the KE projectile as it passes oblique plates. Several plate thicknesses may be entered separated by blank spaces. For each impact angle, Rotation velocity disturbances, W_o , are entered separated by blank spaces. If no Rotation velocity disturbances, W_o are known or wanted, this block can be left empty.

10.4.2.3 Small projectile splinter generation

Small projectile splinter generation is entered in the same way as Jet splinter generation and Secondary splinter generation. Additional parameters are Min. penetration, G_{p2Min} , Max. penetration, G_{p2Max} and Reference velocity, V_{ref} .

10.4.2.4 Large projectile splinter generation

Large projectile splinter generation is entered in the same way as Jet splinter generation and Secondary splinter generation. Additional parameters are Min. penetration, G_{p1Min} , Max. penetration, G_{p1Max} and Reference velocity, V_{ref} .

10.4.2.5 Secondary splinter generation

Secondary splinter generation is entered in the same way as Jet splinter generation and Secondary splinter generation. Additional parameters are Min. penetration, G_{sekMin} , Max. penetration, G_{sekMax} and Reference velocity, V_{ref} .

10.4.2.6 Target specific ERA data (**.dat**)

Data is entered in a similar way as for shaped charge warhead effects.

Crater diameter, R is the crater diameter in the ERA-module if the KE projectile does not initiate it.

In the block ERA initiation probabilities, P_i , initiation probabilities are given as function of impact angles (relative to the surface normal) and impact velocity.

10.4.2.7 Target specific LRA data (**.dat**)

Data is entered in a similar way as for shaped charge warhead effects.

Crater diameter, R is the crater diameter in the LRA-module if the KE projectile does not initiate it.

In the block LRA initiation probabilities, P_i , initiation probabilities are given as function of impact angles (relative to the surface normal) and impact velocity.



10.4.3 Shaped charge with penetrating nose (.hnp)

The shaped charge with penetrating nose is a variant of the shaped charge warhead effect. It is a shaped charge that has a stiff nose attached to aid the penetration of ERA- and LRA-modules. The data needed to create a hard nose projectile warhead effect is therefore very similar to the shaped charge. The differences are mainly in the ERA/LRA- interactions.

Open the pull down menu **Warhead carrier** and select **Warhead effect** and then click on **Shaped charge with penetrating nose...**

Click on the **Open file...** key. Select an existing file or define a new one. It is optional to give it a descriptive title.

Select the different categories and give the necessary input as explained below. Beside every category button there is a checkbox to help you keep track of which data have been completed.

10.4.3.1 Shaped charge data

This is entered in exactly the same way as for an ordinary shaped charge warhead effect.

10.4.3.2 Target specific ERA data (.dat)

Select the target file containing the ERA-module data by clicking **Open target file (.trg)...** The target file name, title and the defined ERA-module types appear in their respective areas.

For each ERA-module type you need to create the interaction file as for the other warhead effect types. You need to input a Channel diameter, R that will be created in the case the stiff nose succeeds to penetrate the ERA-module as intended. You then need to enter some Impact angles, Alpha and, for each selected Impact velocity, V, enter Probabilities for channel in ERA, Pch which are the probabilities that the hard nose will work as intended.

10.4.3.3 Target specific LRA data (.dat)

Enter data for LRA-modules in exactly the same way as for ERA-modules.

10.4.4 Explosively formed projectile (.efp)

Open the pull down menu Warhead carrier and select Warhead effect and then click on Explosively formed projectile....

Click on the Open file... key. Select an existing file or define a new one. It is optional to give it a descriptive title.

Select the different categories and give the necessary input as explained below. Beside every category button there is a checkbox to help you keep track of which data have been completed.

10.4.4.1 Geometry

- Enter the basic geometry data for the explosively formed projectile (EFP).
- Initial velocity and penetration
- Penetration, G and Crater diameter, Dc are entered and edited in the standardised way. Begin with data for 0 m/s.

- Velocity correction, Kv and Mass correction, Km are entered and edited in the standardised way. Both corrections are functions of the Parameter X (used penetration capability fraction).

10.4.4.2 Break-up data

When the EFP passes through a plate (component) there is a possibility that the projectile will break into several parts. This is described in this box.

- Critical thickness for break-up, tk4 is the minimum thickness of a plate or component to initiate break-up of the EFP.
- Standard dev., SigmaSep is the standard deviation of the separation of the formed projectile parts.
- Min. velocity reduction, Vmin and Max. velocity reduction, Vmax are limits for the velocity reduction of the formed projectile parts when they are formed. AVAL will randomise the velocity reduction for each part within the given limits.
- Min. and Max. number of projectile parts are entered as functions of the impact angle.
- Projectile part mass, Km is used to determine the mass of each of the formed projectile parts. Refer to the Reference manual for a complete explanation. Two examples are given in Table 8. In example 1 all formed projectile parts will be given equal masses. In example 2, if two parts are formed, the first is given 70% of the original projectile mass. If more parts are formed, AVAL will make linear interpolations between the given points to determine projectile part masses.

Table 8: Examples of projectile part mass distribution.

| Example 1 | | Example 2 | |
|-----------|----------|-----------|----------|
| 0.0 | 0.000000 | 0.0 | 0.000000 |
| 1.0 | 1.000000 | 0.5 | 0.700000 |
| | | 1.0 | 1.000000 |

Finally you input the Penetration for projectile parts, G data.

10.4.4.3 Projectile splinter data

- Projectile splinter data is entered as for KE projectiles and shaped charges.
- Projectile parts splinter data
- Projectile parts splinter data is entered as for KE projectiles and shaped charges.
- Secondary splinter data
- Projectile splinter data is entered as for KE projectiles and shaped charges.

10.4.4.4 Target specific ERA data (.dat)

Target specific ERA data is input as for shaped charges.

10.4.4.5 Target specific LRA data (.dat)

Target specific LRA data is input as for shaped charges.

10.4.4.6 Fragmenting charge (.frg)

AVAL treats all fragments generated from a fragmenting charge individually. Data need to be supplied for each individual fragment. It is therefore in almost every case necessary to use computer generated fragment data. It is possible to generate fragment data file by



hand, but it is very easy to make mistakes in this way and it is not a recommended method except for very simple cases.

Open the pull down menu **Warhead carrier** and select **Warhead effect** and then click on **Fragmenting charge...**

Click on the **Open file...** key. Select an existing file or define a new one. It is optional to give it a descriptive title.

Select the different categories and give the necessary input as explained below. Beside every category button there is a checkbox to help you keep track of which data have been completed.

Files cont. data for fragments (*.dat*) and aero data (*.dat*)

AVAL can generate the necessary data files based upon either:

- SplitX version 5.0
- FragM
- Experimental data

AVAL reads the file line by line and checks the number of values only. No control is made for unreasonable data. It is therefore important for the user to be very careful when creating the input file. The format for the fragment data file is found in the File format document.

Note:

- The direction (xDir, yDir, zDir) must not be 0, 0, 0.
- The velocity must be larger than 0.

10.4.4.7 Penetration data

Enter the penetration data for the fragments from the fragmenting charge.

Note: The factor *c* for calculating crater diameter must not be 0 since this gives a discontinuous change of crater diameter.

10.4.4.8 Fragment splinter data

Enter data as for other splinter data.

10.4.4.9 Secondary splinter data

Enter data as for other secondary splinter data.

10.4.5 High explosive charge (*.hex*)

Open the pull down menu **Warhead carrier** and select **Warhead effect** and then click on **High explosive charge...**

Click on the **Open file...** key. Select an existing file or define a new one. It is optional to give it a descriptive title.

Enter the Total mass in actual high explosive material.

Enter the Correction factor for Equivalent TNT-mass for blast effect calculation.

Enter the Correction factor for mass contributing to pressure.

10.5 Warhead (.whd)

In this section you will construct the warhead. The warhead will consist of one or more warhead effects. Example: an anti-aircraft missile can have a warhead consisting of a fragmenting charge warhead effect and a high explosive warhead effect.

Open the pull down menu **Warhead carrier** and then click on **Warhead....**

Click on the **Open file...** key. Select an existing file or define a new one. It is optional to give it a descriptive title.

In the block Define warhead effects, you will select the different warhead effects that define the warhead.

Give the warhead effect a Number and a Reference position, X (in the warhead coordinate system). Define orientations Psi (rotation around the z-axis) and Theta (rotation around the y-axis).

Click **Select warhead effect...** and select the warhead effect you want to add. In the "file format" box (Windows standard) you can select which warhead effect to search for.

Add the selected warhead effect by clicking **Add**.

Repeat the steps until all warhead effects are added to the warhead.

Save the file and exit.

10.6 Warhead carrier (.wcf)

This is where it all comes together in defining the final warhead carrier. The warhead carrier consists of two main subsystems; a fuze system and one or more warhead(s).

Open the pull down menu **Warhead carrier** and then click on **Warhead carrier....**

Click on the **Open file...** key. Select an existing file or define a new one. It is optional to give it a descriptive title.

Select the fuze system by clicking **Select .fze file...** and select the appropriate file.

Define warheads by entering appropriate data for Time delay, Position and Orientation. Mark checkboxes for Used for internal burst and Tandem warhead as needed. Add the warhead by selecting the warhead file and clicking Add. Repeat until all warheads are added.

If the warhead carrier shall be used as a threat in an automatic protection system (APS) simulation than the button **Data for calc. effects on active protection system (APS) ...** need to be pressed. A new dialogue appears where three different files are defined:

- A file containing a target description for the warhead carrier according to AVAL:s nomenclature.
- A file containing data for critical events, format defined in chapter 10.
- A file containing data for a trajectory, format defined in chapter 10.

Save the file and exit.

Make sure that no warhead effect or part of warhead effect is located in front of or exactly in an impact sensor point. This may otherwise result in false penetration- and fragmentation calculation.



To be certain that the position always is right relocate the warhead effect in the warhead or the warhead in the warhead carrier to 0.001 m behind any point of the impact sensor.

10.6.1 Data for critical events for a threat in an APS-simulation

Fault tree events connected to the performances for the threat (critical events) are calculated during APS-simulations. The following types of events are used in these calculations:

- The reduction for warhead effect penetration capability.
- The miss function for sensor(s). The sensor is not function properly if the fault tree event has occurred.
- The radial miss distance. Standard deviation is defined as a function of distance.

Example of input data for a file with data for critical events is found in the File format document.

10.6.2 Data for trajectory for a threat in an APS-simulation

Trajectories can be defined for as well guided as unguided projectiles. A trajectory for the threat is read from a file which contains the following data for each flight time (tb):

- Flight distance
- Side deviation
- Height
- Velocity in length direction
- Velocity in side direction
- Velocity in height direction
- Roll angle
- Roll rate

The direction for the threat is always assumed to be equal to the velocity vector. In calculations the trajectory is transformed to the target coordinate system. The transformation is using the randomized hit point and the direction in terms of bearing and elevation. The endpoint for the trajectory is then always situated at the hit point. The direction of the trajectory D-axis in target coordinate system is defined by bearing and elevation angles.

Example of input data for a trajectory is found in the File format document.

10.7 Laser weapons (.law)

Note:

The experience of using Laser weapons, HPM weapons and EMP weapons in AVAL simulations is limited. Therefore the work with how these weapons should be described is continuing, and the sections 10.6 Laser weapons, 10.7 HPM weapons and 10.8 EMP weapons in this manual are to be considered as preliminary.

Open the pull down menu **Modes** and click on **Single Target...** . An empty window (Target No. 1) is opened.

Open the pull down menu **Single simulation** and select **EM weapons, Laser** and then click on **Define...** The Laser weapon dialogue box is opened, which contains all data for a laser weapon.

Click on the **Open file...** key. Select an existing file or define a new one. It is optional to give it a descriptive title.

Data for laser weapon position.

Bearing angle and elevation angle are given in the target co-ordinate system. This means that a bearing angle between 0 and 3.1416 corresponds to a hit in the target left hand side and an elevation angle between 0 and 3.1416 corresponds to a hit in the target from above. The distance from the weapon to the target is given.

Aim point in target

The aim point is described in the target co-ordinate system. The location of the co-ordinate system can be viewed in the Target program module. Read the target, and click the **Plot co-ordinate axis** in the **Plot** options-menu.

Deviation for laser shot

This deviation should reflect how well the weapon is pointed at the aim point and include errors from the gunner as well as the sighting device.

Deviation per laser pulse

This describes the deviation between single pulses with a perfectly aimed weapon.

Firing data for one MC-cycle

Here you can describe the firing sequence as salvos of shots or single shots. The default values 1, 1, 0 taken downwards correspond to a single shot. The time data could be used to describe different time for the gunner to aim and fire. The data 5, 100, 0 describes a firing with 5 shots fired with the speed of 100 shots per second.

Laser source

Here you can describe that the laser shots are of a pulsed or a continuous type. The choice affects the need for data in the next step.

Laser weapon, shot and pulse data

For laser shots of a continuous type the following data are required:

Exposure time per laser shot describes the duration for one laser shot. Wavelength is the wavelength of the laser radiation. Output power is the power of the laser transmitter. The laser beam Divergence is also described.

For laser shots of a pulsed type the effect is described by Pulse length, Pulse repetition frequency and Pulse energy instead of Output power.

Atmosphere data

Turbulence conditions are described by choosing one of the predefined turbulence levels **Winter**, **Summer day** and **Summer night**. The Visual sight is described.

Save data and exit the Laser weapon dialogue or describe another laser weapon.

10.8 HPM weapons (.hpm)

Note:

The experience of using Laser weapons, HPM weapons and EMP weapons in AVAL simulations is limited. Therefore the work with how these weapons should be described is continuing, and the sections 10.6 Laser weapons, 10.7 HPM weapons and 10.8 EMP weapons in this manual are to be considered as preliminary.



Open the pull down menu **Modes** and click on **Single Target....** . An empty window (Target No. 1) is opened.

Open the pull down menu **Single simulation** and select **EM weapons, HPM** and then click on **Define....** The HPM weapon dialogue box is opened, which contains all data for a HPM weapon.

Click on the **Open file...** key. Select an existing file or define a new one. It is optional to give it a descriptive title.

Data for HPM weapon position.

Bearing angle and elevation angle are given in the target co-ordinate system. This means that a bearing angle between 0 and 3.1416 corresponds to a hit in the target left side and an elevation angle between 0 and 3.1416 corresponds to a hit in the target from above. The distance from the weapon to the target is given.

Aim point in target

The aim point is described in the target co-ordinate system. The location of the co-ordinate system can be viewed in the Target program module. Read the target, and click the **Plot co-ordinate** axis in the **Plot** options-menu.

Deviation for HPM shot

This deviation should reflect how well the weapon is pointed at the aim point and include errors from the gunner as well as the sighting device.

Deviation per HPM pulse

This describes the deviation between single pulses in a shot with a perfectly aimed weapon.

Firing data for one MC-cycle

Here you can describe the firing sequence as salvos of shots or single shots. The default values 1, 1, 0 taken downwards correspond to a single shot. The time data could be used to describe different time for the gunner to aim and fire. The data 5, 100, 0 describes a firing with 5 shots fired with the speed of 100 shots per second.

HPM weapon, shot and pulse data.

Exposure time per HPM shot describes the duration for one HPM shot. Power is the power of the HPM weapon and Gain describes the antenna efficiency. Pulse length, Pulse repetition frequency and Frequency for the HPM source are also given.

Save data and exit the HPM weapon dialogue or describe another HPM weapon.

10.9 EMP Weapons (.emp)

Note:

The experience of using Laser weapons, HPM weapons and EMP weapons in AVAL simulations is limited. Therefore the work with how these weapons should be described is continuing, and the sections 10.6 Laser weapons, 10.7 HPM weapons and 10.8 EMP weapons in this manual are to be considered as preliminary.

Open the pull down menu **Modes** and click on **Single Target...** . An empty window (Target No. 1) is opened.

Open the pull down menu **Single simulation** and select **EM weapons, HPM** and then click on **Define...** . The HPM weapon dialogue box is opened, which contains all data for a HPM weapon.

Click on the **Open file...** key. Select an existing file or define a new one. It is optional to give it a descriptive title.

Data for EMP weapon position.

The position, bearing angle and elevation angle of the EMP source are given in the target co-ordinate system. This means that a bearing angle between 0 and 3.1416 corresponds to a hit in the target left side and an elevation angle between 0 and 3.1416 corresponds to a hit in the target from above. The deviation of source position and direction should reflect how well the weapon is pointed at the target.

EMP weapon, shot and pulse data

Exposure time per EMP shot describes the duration for one HPM shot. Power is the power of the EMP weapon and Gain describes the antenna efficiency. Pulse length, and Frequency for the EMP source are also given.

Save data and exit the HPM weapon dialogue or describe another HPM weapon.



11 Tools

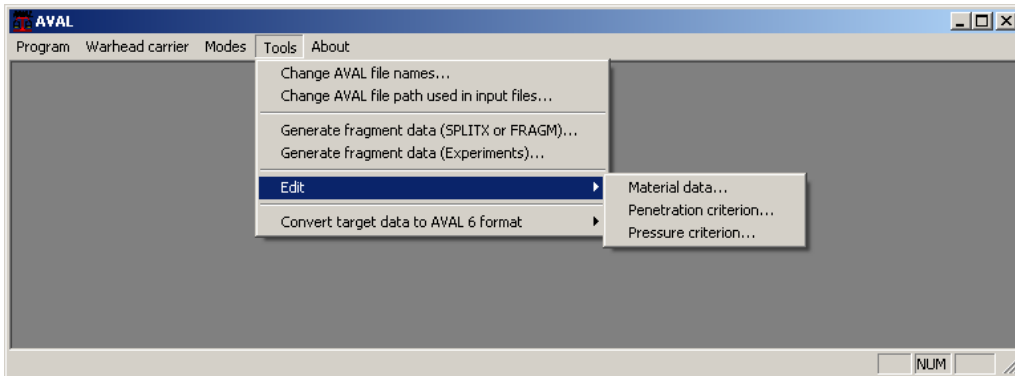

Figure 64: AVAL built in tools.

11.1 Change AVAL file name

This tool is used for changing the name for all files included in an AVAL directory. This is very useful when renaming for example target files or weapon files.

Open the pull down menu **Tools** and click on **Change AVAL file name...**. The dialogue box Change AVAL file names, Figure 65, is opened.

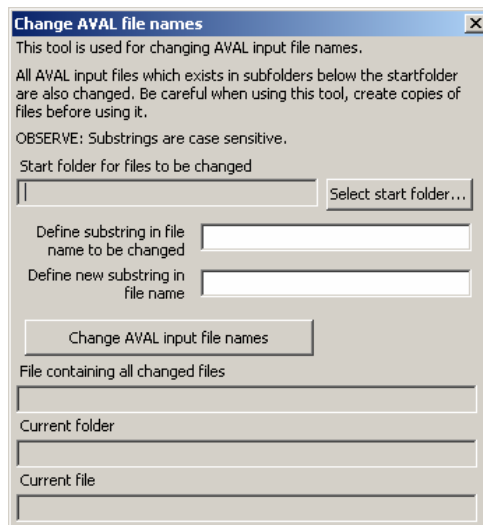

Figure 65: The Change AVAL file names dialogue box.

Click on the **Select start folder...** key and select the folder to change.

Enter the substring to be changed.

Enter the new substring to replace the old one with, and click on the **Change AVAL input files** key.

Close the Change AVAL file names dialogue box with the **X** at the top right corner.

A log file is created where you can see which files that are changed.

11.2 Change AVAL file path used in input files

This tool is used for automatic change of drive letter, i. e. *C:* to *F:* or library name i.e. *C:\A61* to *C:\A61-Project name*. These paths are in AVAL data files written within apostrophes (' '). The tool works as a search and replace function in all AVAL file types and is limited to path expressions within apostrophes.

Open the pull down menu **Tools** and click on **Change AVAL file path used in input files...**. The dialogue box Change path name in AVAL files, figure 66, is opened.

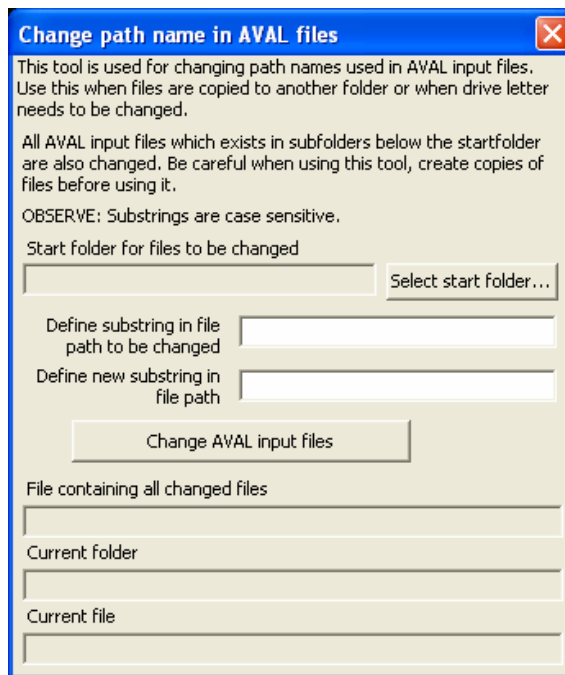

Figure 66: The Change path name in AVAL files dialogue box.

Click on the **Select start folder...** key and select the folder to change (e.g. *A61*).

Enter the substring to be changed (e.g. *C:\A61*)

Enter the new substring to replace the old one with (e.g. *F:\A61* or *C:\A61 Project name*), and click on the **Change AVAL input files** key.

Close the Change path name in AVAL files dialogue box with the **X** at the top right corner.

A log file is created where you can see which files that are changed.

11.3 Generate fragment data (SPLITX or FRAGM)

The following dialogue, Figure 67, appears when this option is selected:

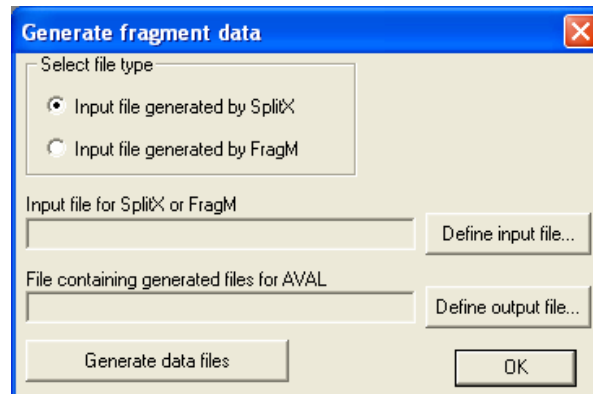

Figure 67: The generate fragment data dialog box.

This dialogue is used generating fragment data for AVAL:s format. Output data from two different programs is handled, SplitX and FragM.

11.3.1 Input data for SplitX

SplitX is a standalone commercial program used for generating fragment data from 2-dimensional natural- and pre fragmented charges. This module reads output data generated from SplitX version 5 and 6. Some small changes can be needed in order to have the .pit-file looking as in Figure 68. The shape of a fragment can be one of the following types:

- Cube
- Cylinder
- Multi-P
- Natural
- Notched
- Rectangular
- Rod
- Sphere

```

$(06-06-01 14:20:37) SPLIT-X 5.13.1, CPU
$
$......PROJECTILE INTERFACE
$
TITLE;Name
MATERIAL;1;Steel M42A1 (Exp);128;128;0;1;7.85
TABLE;1;11;DRAG(Steel M42A1 (Exp))
0;1.08
0.61;1.08
0.82;1.12
1.02;1.24
1.23;1.36
1.43;1.4
1.64;1.4
2.05;1.36
3.07;1.28
5.12;1.2
9.22;1.12
PROJECTILE;1;3;1;1;12.6057;4.35395;8.61047
POSITION;1;34.0709;56.1773;13.9134;-1.32773;-0.206378;0
VELOCITY;1;-534.007;1520.98;376.696;0;0;0
TIME;1;178.231;21.649
PROJECTILE;2;3;1;1;17.1183;5.91257;8.61047
POSITION;2;38.4304;57.0723;14.0051;-1.32989;-0.206378;0
VELOCITY;2;-533.481;1531.23;375.748;0;0;0
...
    
```

Figure 68: The beginning of a SplitX file adjusted to be readable by AVAL.

11.3.2 Input data for FragM

FragM is an addition to the DYNA-3D code. Warheads with arbitrary geometry and fragment types can be generated. Data for all types of warheads can be used by AVAL. The resulting file from FragM needs to be modified in two ways:

- A new extension: *.fgm*
- Modification of the content as follows.

The modification of the content is slightly different for the three types of warheads:

- Rotation symmetric warhead
- Rectangular fragmenting plate
- Elliptical fragmenting plate.

11.3.2.1 Warheads with rotational symmetry

In FragM a rotationally symmetrical warhead is described by a number of axial parts, Figure 69. The direction and velocity for fragments are calculated by DYNA-3D by giving the velocity vector in the interfaces between the parts. Data for individual fragments are interpolated based on their respective positions in the warhead. Penetration capability for fragments emanating from different parts of the warhead is measured in tests. Based on penetration capability and velocity the masses for individual fragments are calculated.

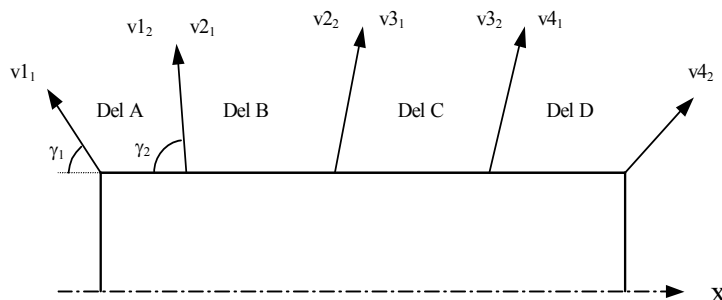

Figure 69: Warhead rotational symmetry in FragM.

The input file format from FragM for a rotationally symmetrical warhead is described in the File format document.



11.3.2.2 Warheads with rectangular fragmenting plates

In FragM the fragments on a rectangular fragmenting plate are placed on the surface of a half cylinder with a user selectable radius. The half cylinder is divided into a number of sectors, axially and tangentially. The fragments are equally distributed among the sectors.

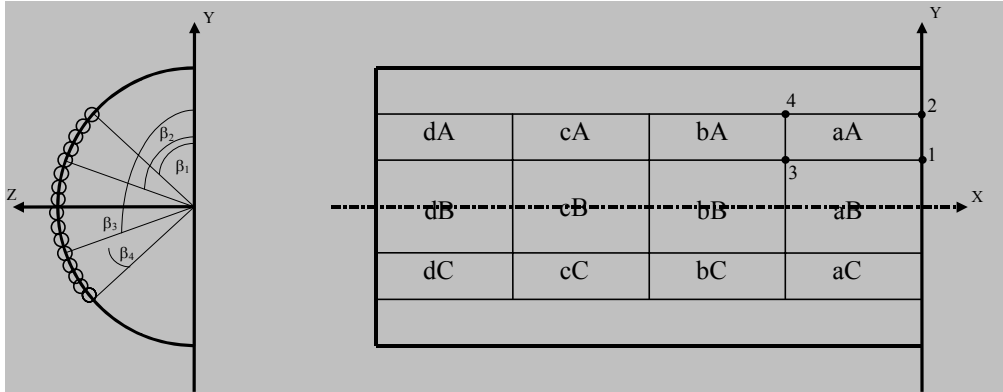

Figure 70 Warheads with rectangular fragmenting plates in FragM.

The directions and velocities for fragments are calculated by DYNA-3D and described by the velocity vector in each of the sectors' corners. Data for individual fragments are interpolated based on their respective positions in the warhead. Penetration capability for fragments emanating from different parts of the warhead is measured in tests. Based on penetration capability and velocity the masses for individual fragments are calculated.

The input file format from FragM for a rectangular fragmenting plates fragmenting warhead is described in the File format document.

11.3.2.3 Warheads with elliptical fragmenting plates

In FragM the fragments are defined in a plane elliptical surface. The origin is placed in the centre of the ellipse with the z-axis directed in the same direction as the ellipse's normal vector. The ellipse is divided into radial and tangential sectors. The fragments are randomly distributed within the sectors according to a rectangular distribution. The ellipse is defined by its two half-axis. The directions and velocities for fragments are calculated by DYNA-3D and described by the velocity vector in each of the sectors' corners. Data for individual fragments are interpolated based on their respective positions in the warhead. Penetration capability for fragments emanating from different parts of the warhead is measured in tests. Based on penetration capability and velocity the masses for individual fragments are calculated.

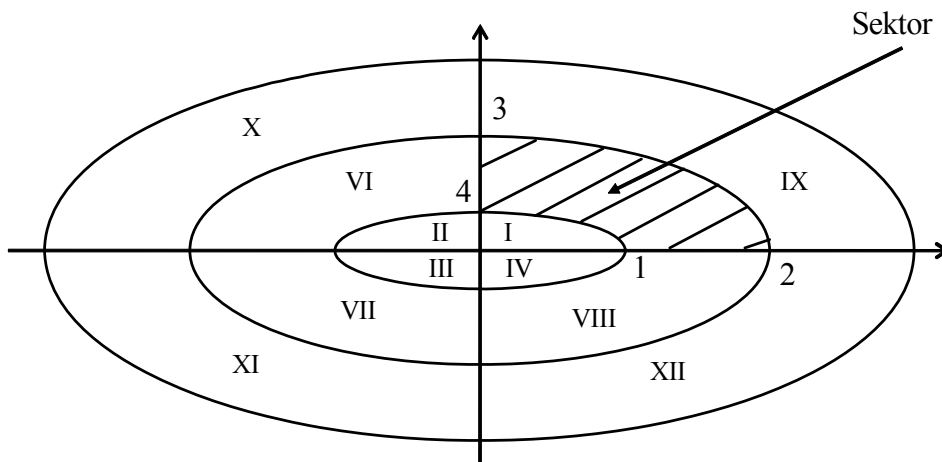

Figure 71 Warheads with elliptical fragmenting plates in FragM.

The input file format from FragM for an elliptical fragmenting plates fragmenting warhead is described in the File format document.

11.3.3 Generate fragment data (Experiments)

The following dialogue, Figure 72, appears when this option is selected:

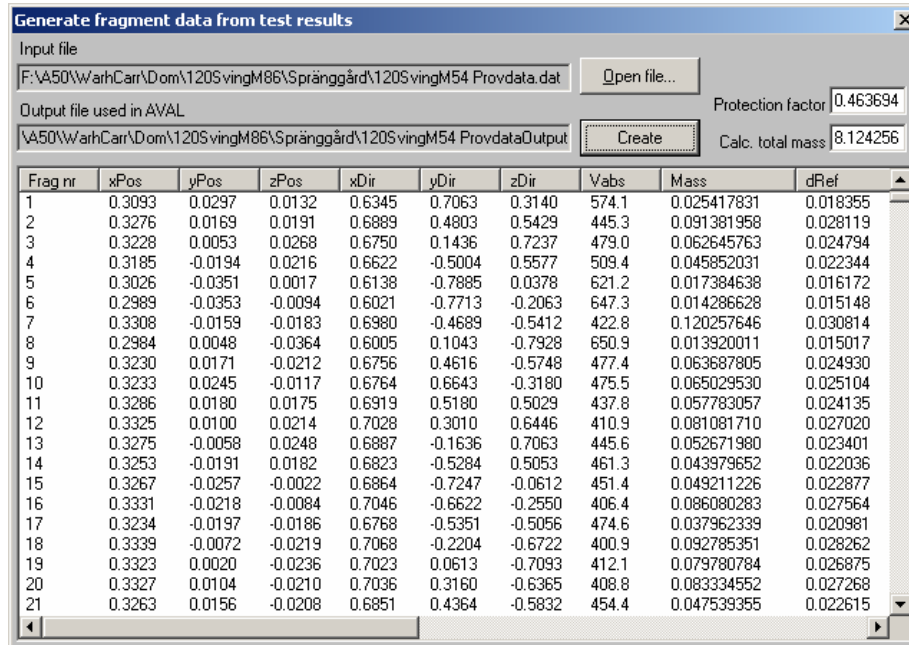

Figure 72 The Generate fragment data from test results dialog box.

This dialogue is used for generating fragment data for AVAL. Output data from an experiment is read from the input file. An example is used for demonstrating the input data. Consider a simple case divided in three segments as shown in Figure 73.

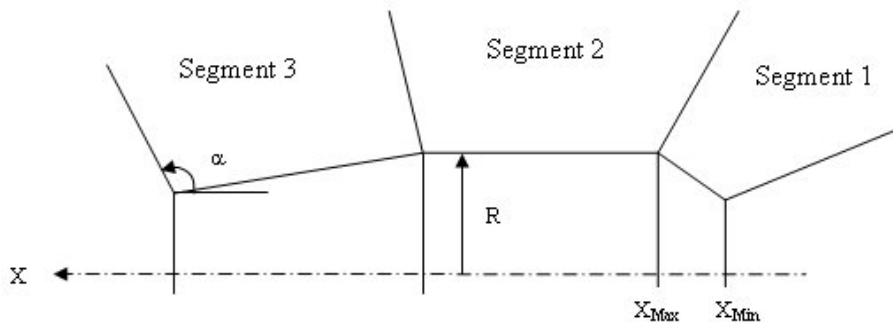

Figure 73 Example of a simple case divided into three segments.

The following data must be defined for each segment:

- Angle for plate relative to x-axis for the shell.
- Min and max x-coordinate, (X_{Min}, X_{Max})
- Radius for case R at X_{Min} and X_{Max}
- Angle for direction α at X_{Min} and X_{Max}
- Velocity for case at X_{Min} and X_{Max}
- Number of penetrated plates
- Number of penetrations in each plate



In the beginning of the file is a title defined. The density for the case is used for calculating the mass for each fragment. Constants for the penetration equation are used for calculating the mass for each fragment. Data for each fragment are displayed in columns and the total mass of the casing is calculated and presented in the dialogue. The result file is generated in AVAL format.

The input file format from a fragment experiment is described in the File format document.

11.4 Edit

The following data is can be changed in dialogues:

- Material data
- Data for penetration criterions
- Data for pressure criterions

11.4.1 Edit material data

The following dialogue is displayed, Figure 74.

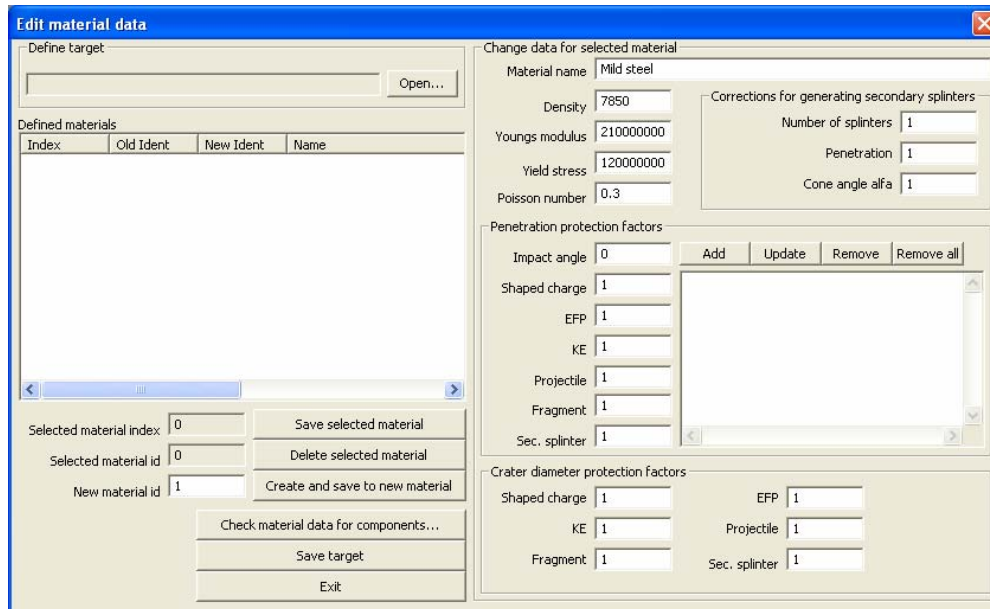

Figure 74 The Edit material dialogue box.

All data for a material might be changed and stored on file. Even a new material can be inserted. There is also a function built in which checks and display all used material data for components. This is performed when pressing button: **Check material data for components.**

The following dialogue appears, see Figure 75:

| Type | Name | Used Materials | Undef. materials |
|--------------------------------|-----------------------------|----------------|------------------|
| 1 - Structure no. 1 (Hollow) | Po1 Radome | 1 | |
| 2 - Structure no. 2 (Hollow) | Po2 Forward bay | 1 | |
| 3 - Structure no. 3 (Hollow) | Po3 Front window | 1 | |
| 4 - Structure no. 4 (Hollow) | Po4 Canopy | 1 | |
| 5 - Structure no. 5 (Hollow) | Po5 Cabin | 1 | |
| 6 - Structure no. 6 (Hollow) | Po6 Forward air intake R | 1 | |
| 7 - Structure no. 7 (Hollow) | Po7 Forward air intake L | 1 | |
| 8 - Structure no. 8 (Hollow) | Po8 Aft bay | 1 | |
| 9 - Structure no. 9 (Hollow) | Po9 Gun | 1 | |
| 10 - Structure no. 10 (Hollow) | Po10 Landing gear | 1 | |
| 11 - Structure no. 11 (Hollow) | Po11 Forward ridge | 1 | |
| 12 - Structure no. 12 (Hollow) | Po12 Wing attachment | 1 | |
| 13 - Structure no. 13 (Hollow) | Po13 Aft ridge | 1 | |
| 14 - Structure no. 14 (Hollow) | Po14 Aft body | 1 | |
| 15 - Structure no. 15 (Hollow) | Po15 R side of aft body | 1 | |
| 16 - Structure no. 16 (Hollow) | Po16 L side of adt body | 1 | |
| 17 - Structure no. 17 (Hollow) | Po17 R aft side of aft body | 1 | |
| 18 - Structure no. 18 (Hollow) | Po18 L aft side of aft body | 1 | |
| 19 - Structure no. 19 (Hollow) | Po19 Nozzle | 1 | |
| 20 - Structure no. 20 (Hollow) | Po20 Air brake R | 1 | |
| 21 - Structure no. 21 (Hollow) | Po21 Air brake L | 1 | |
| 22 - Structure no. 22 (Hollow) | Po23 Air channel R | 1 | |
| 23 - Structure no. 23 (Hollow) | Po24 Air channel L | 1 | |
| 24 - Structure no. 24 (Hollow) | Po25 Air channel center | 1 | |
| 25 - Structure no. 25 (Hollow) | Po26 Air channel aft | 1 | |
| 26 - Structure no. 26 (Hollow) | Po40 Cabin floor | 1 | |
| 27 - Structure no. 27 (Hollow) | Po41 Rack support | 1 | |

Figure 75 The Check components dialogue box.

11.4.2 Edit penetration criterion

Same function as for editing material data, but applied for penetration criterions.

11.4.3 Edit pressure criterion

Same function as for editing material data, but applied for pressure criterions.



12 Menu structure

This chapter shows the complete AVAL menu structure.

12.1 AVAL main menu options

Figure 76 - Figure 81 shows all information in AVAL's main menus.

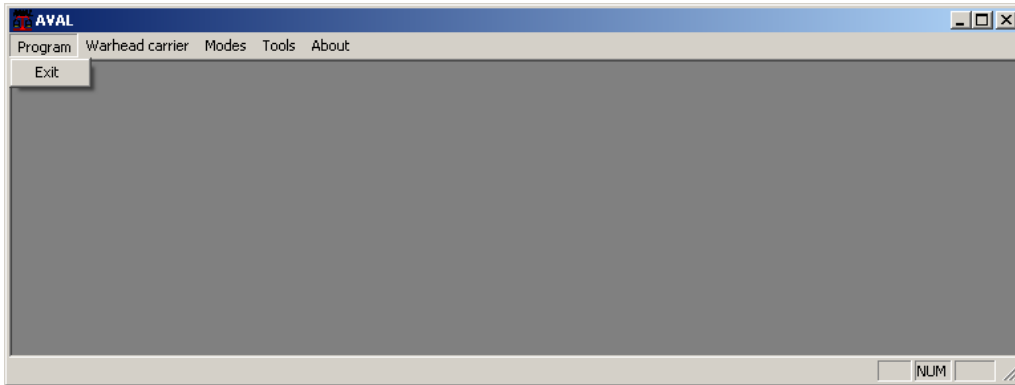

Figure 76 AVAL main menu / Program.

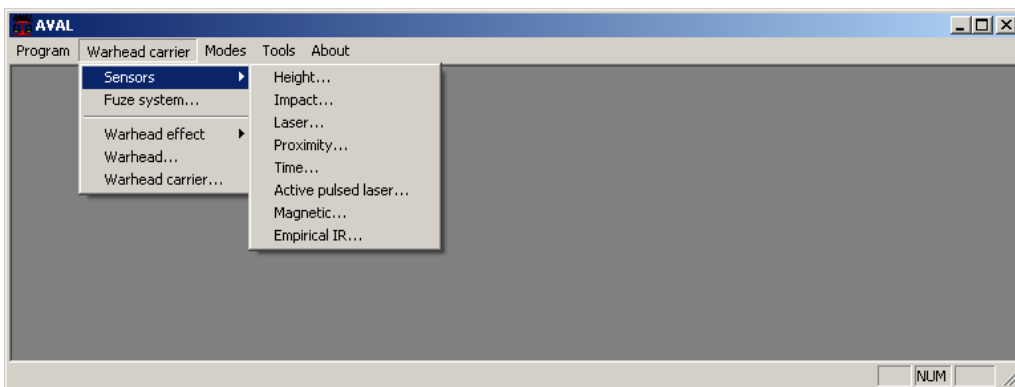

Figure 77 AVAL main menu / Warhead carrier / Sensors

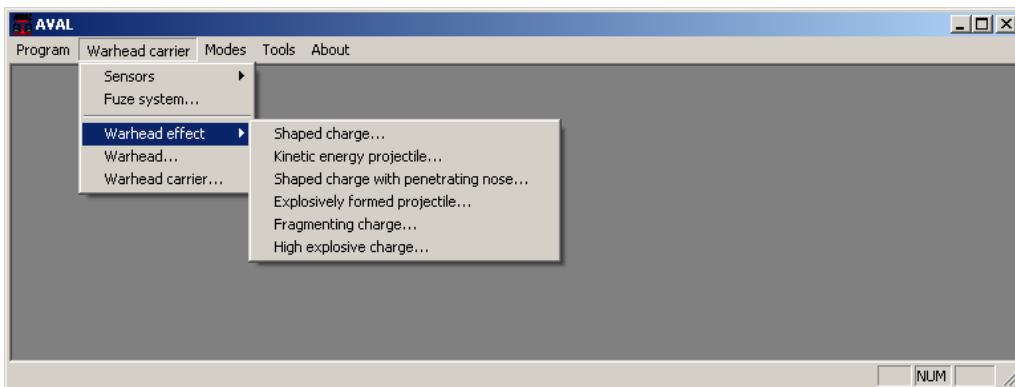

Figure 78: AVAL main menu / Warhead carrier / Warhead effect.

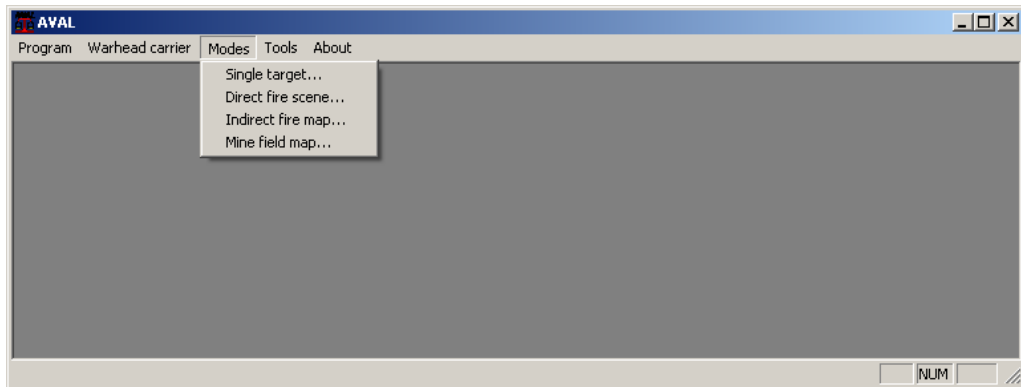

Figure 79: AVAL main menu / Modes.

The **Indirect fire map** is an optional mode and the **Direct fire scene** and the **Mine field map** are both in a development phase.

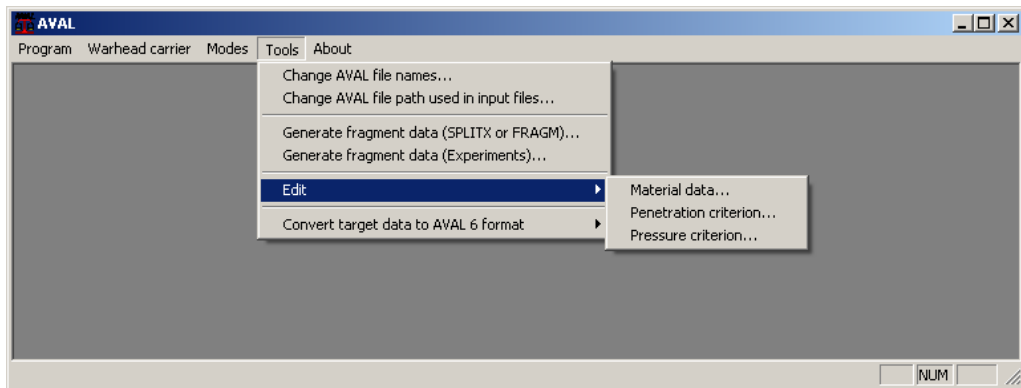

Figure 80: AVAL main menu / Tools / Edit.

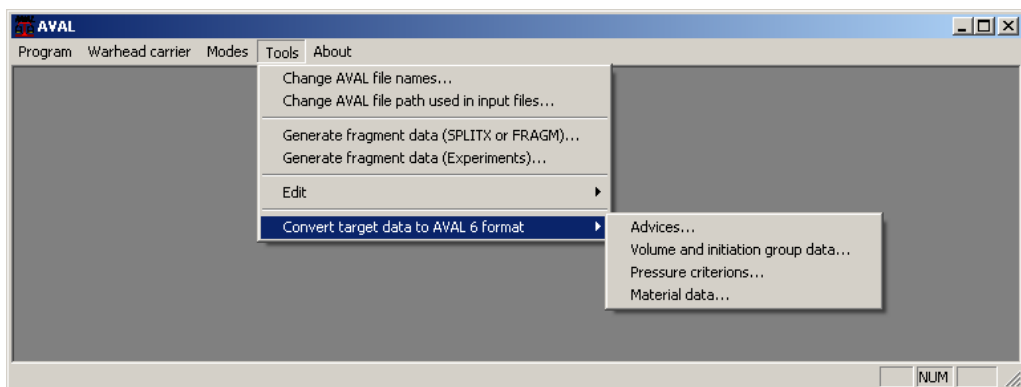

Figure 81: AVAL main menu / Tools / Convert target data to AVAL 6 format.



12.2 Single target menu options

Figure 82 - Figure 95 shows all information in AVAL's Single Target menus.

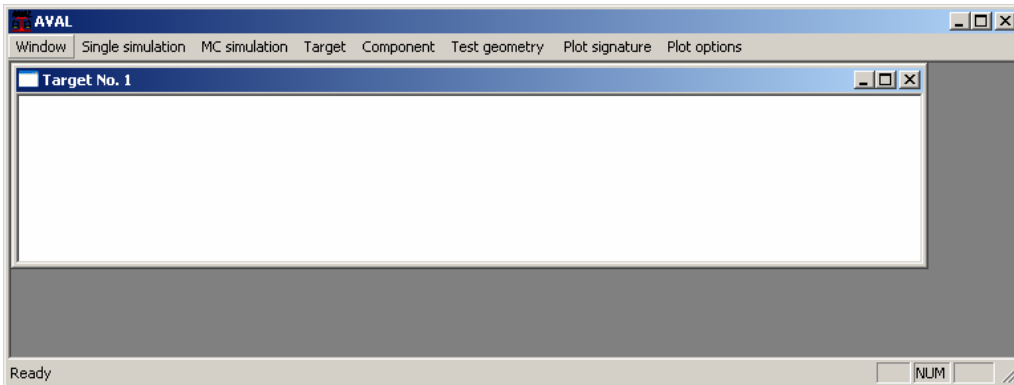

Figure 82 AVAL Single target menu / Window.

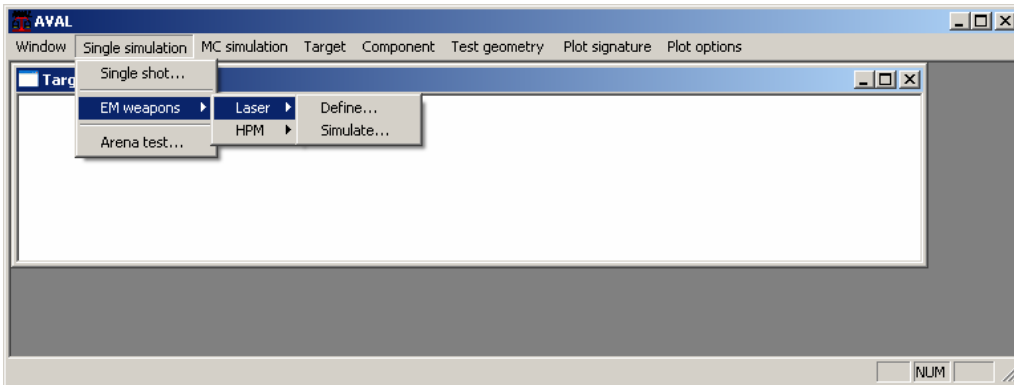

Figure 83 AVAL Single target menu / Single simulation / EM weapons / Laser.

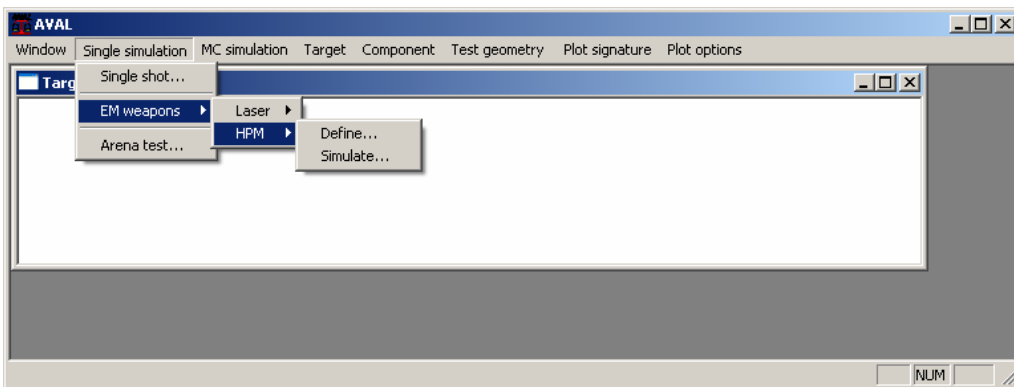

Figure 84 AVAL Single target menu / Single simulation / EM weapons / HPM.

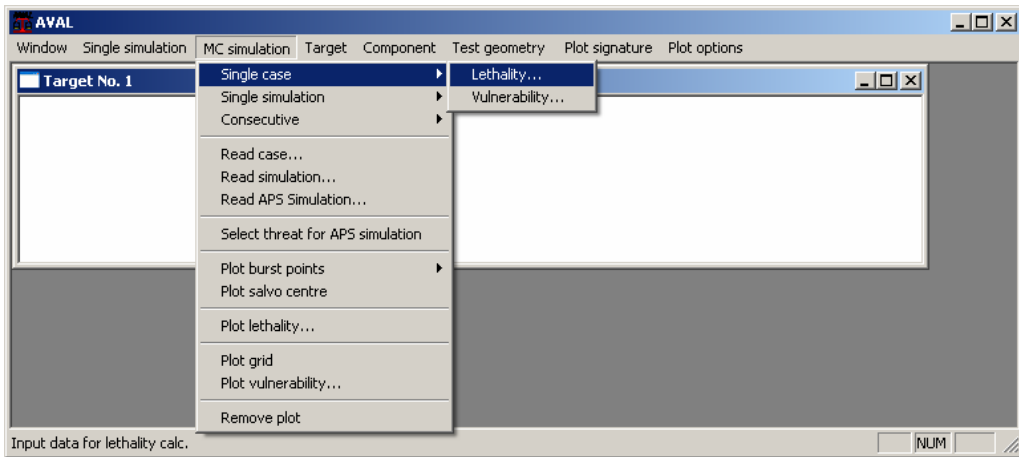

Figure 85 AVAL Single target menu / MC simulation / Single case.

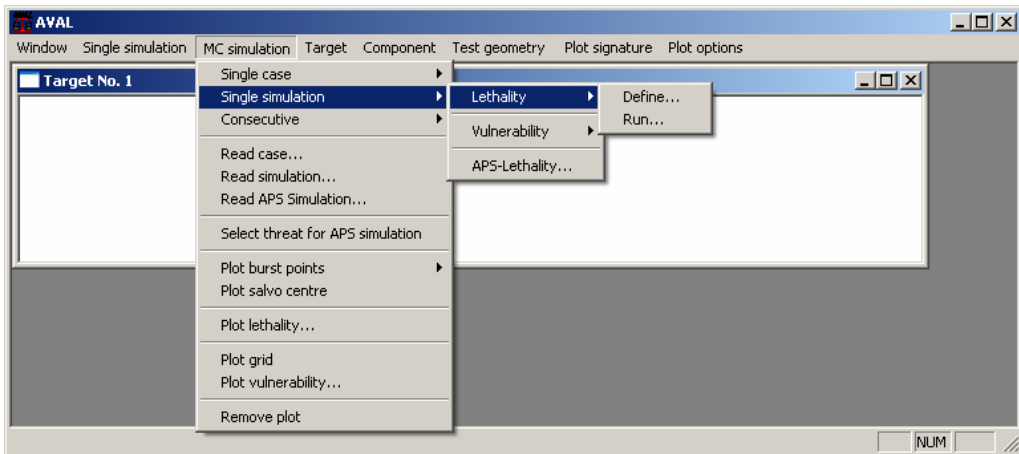

Figure 86 AVAL Single target menu / MC simulation / Single simulation / Lethality.

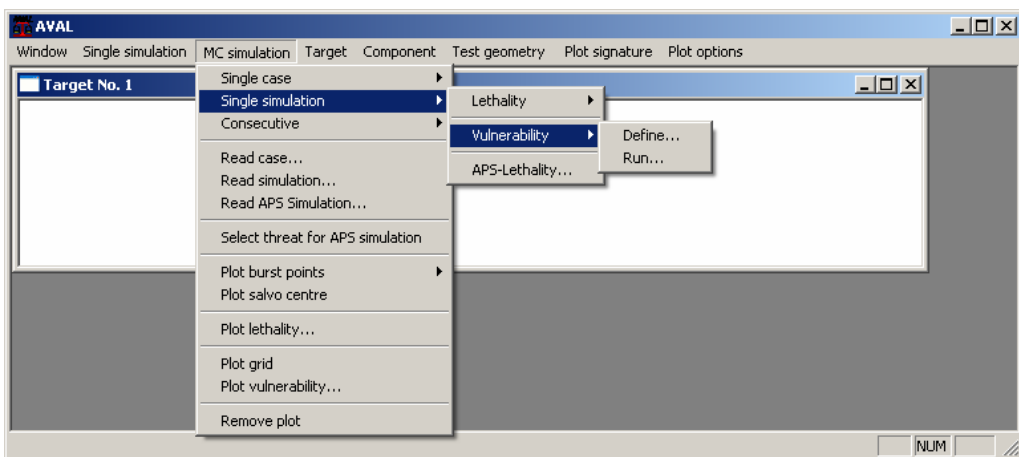

Figure 87 AVAL Single target menu / MC simulation / Single simulation / Vulnerability.

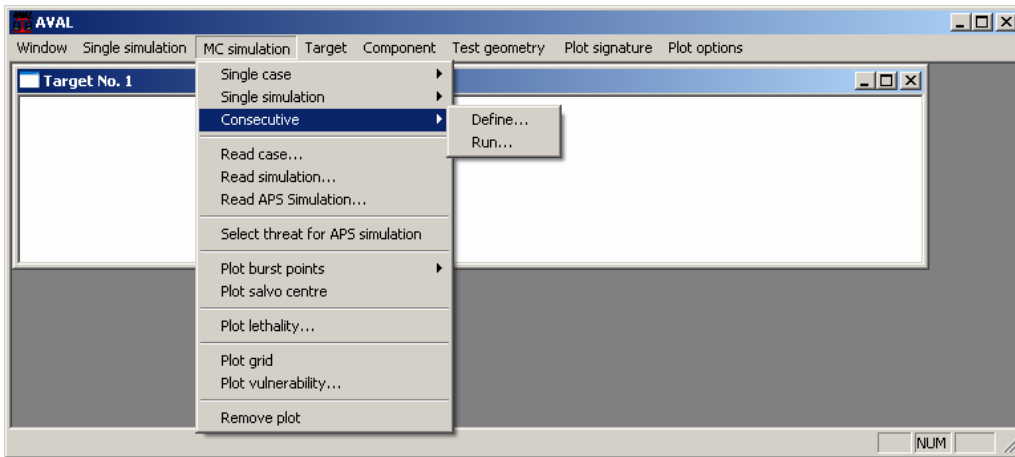

Figure 88 AVAL Single target menu / MC simulation / Consecutive.

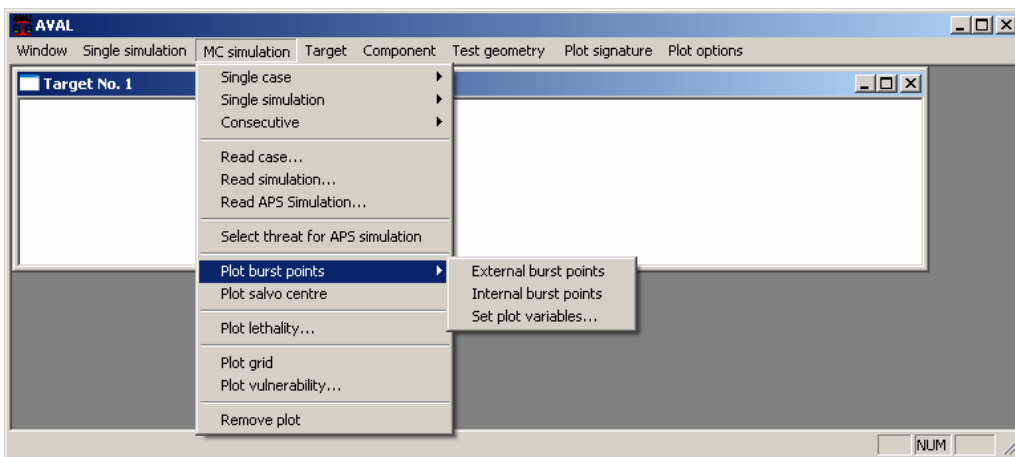

Figure 89 AVAL Single target menu / MC simulation / Plot burst points.

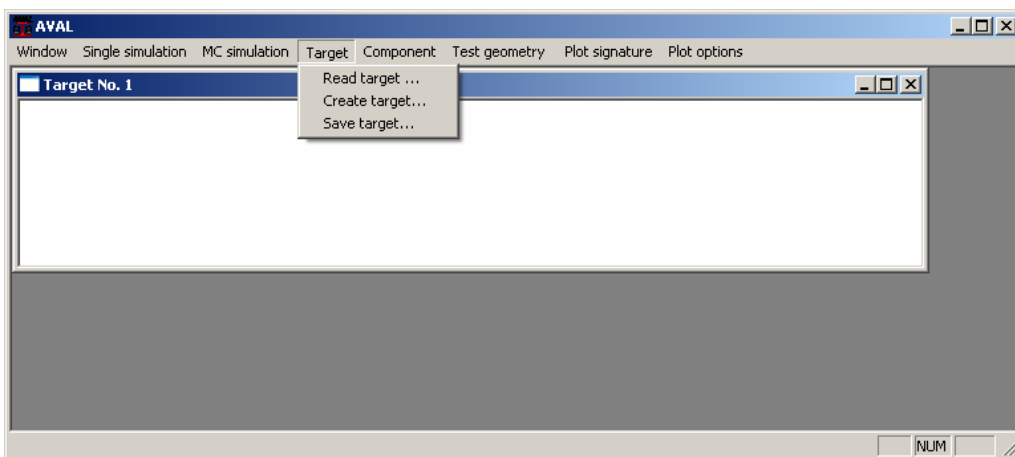

Figure 90 AVAL Single target menu / Target.

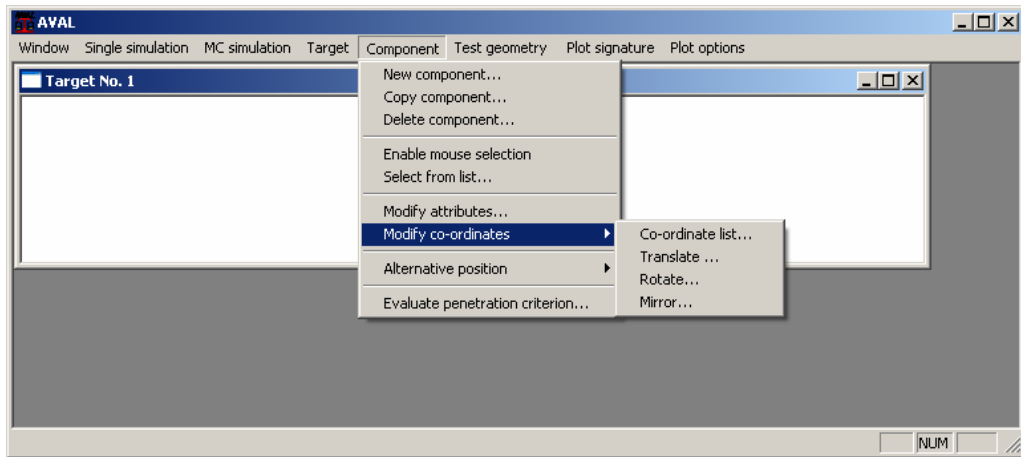

Figure 91 AVAL Single target menu / Component / Modify co-ordinates.

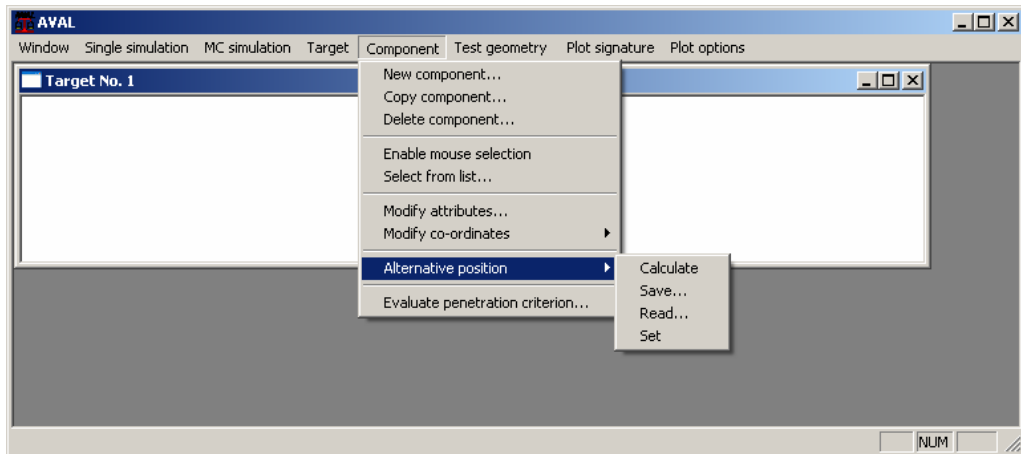

Figure 92 AVAL Single target menu / Alternate position.

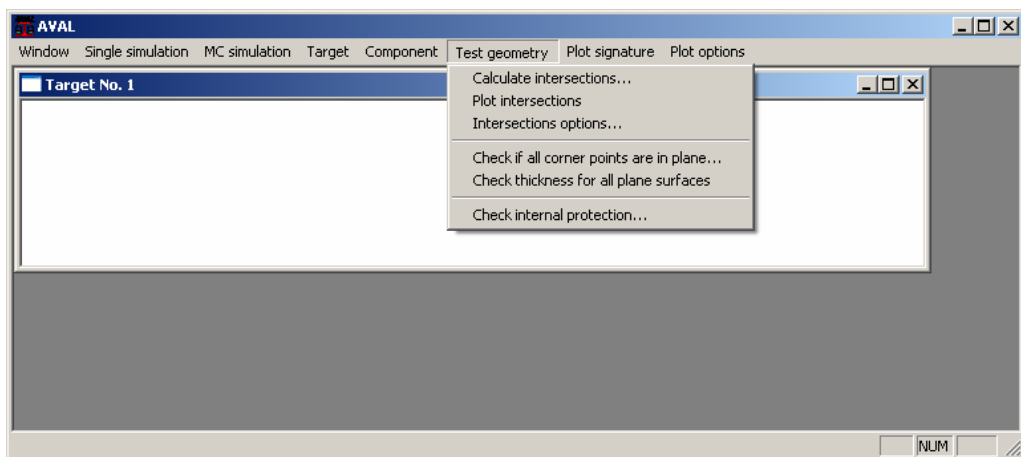

Figure 93 AVAL Single target menu / Test geometry.

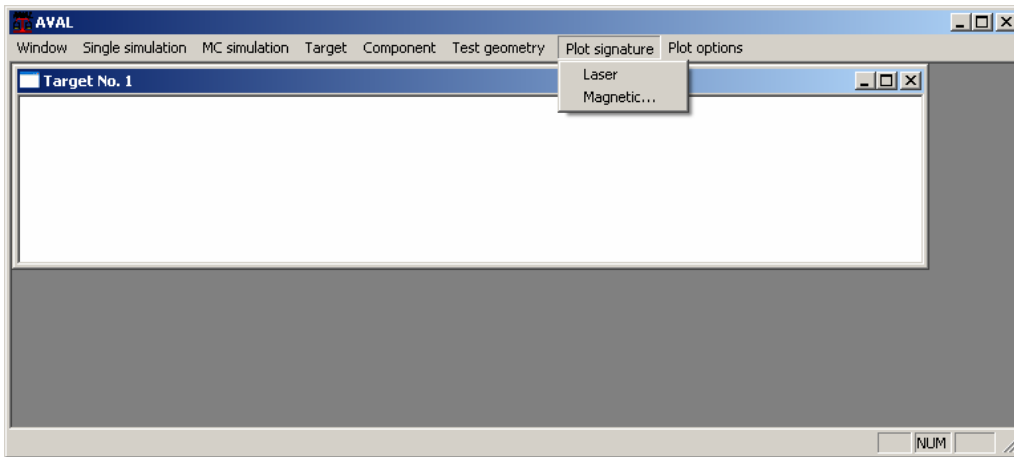

Figure 94 AVAL Single target menu / Plot signature.

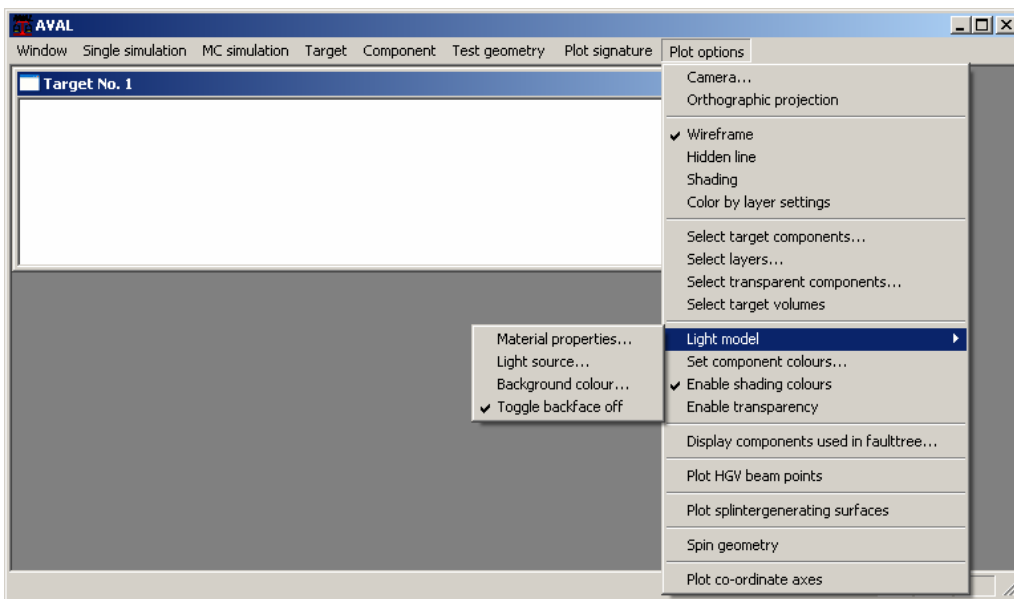

Figure 95 AVAL Single target menu / Plot options / Light model.

12.3 Indirect fire map menu options

Figure 96 - Figure 101 shows all information in AVAL's Indirect Fire menus.

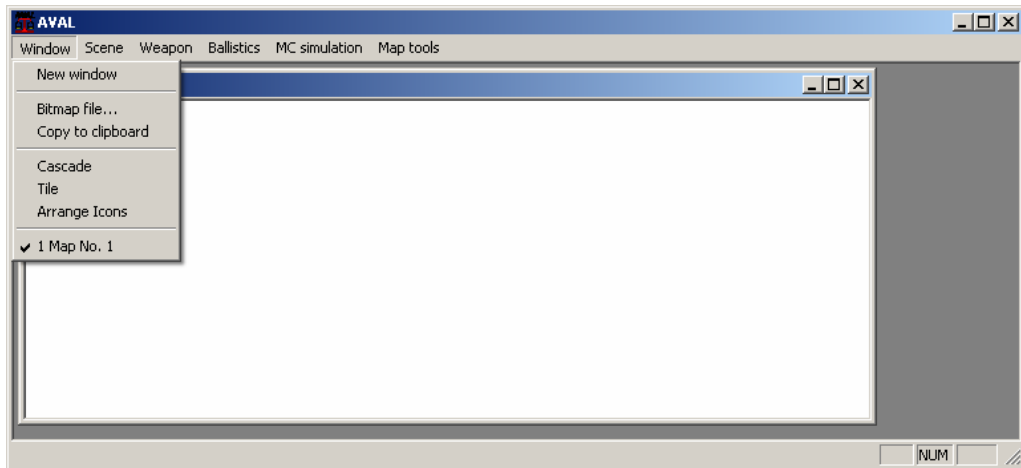

Figure 96 AVAL Indirect fire map menu / Window.

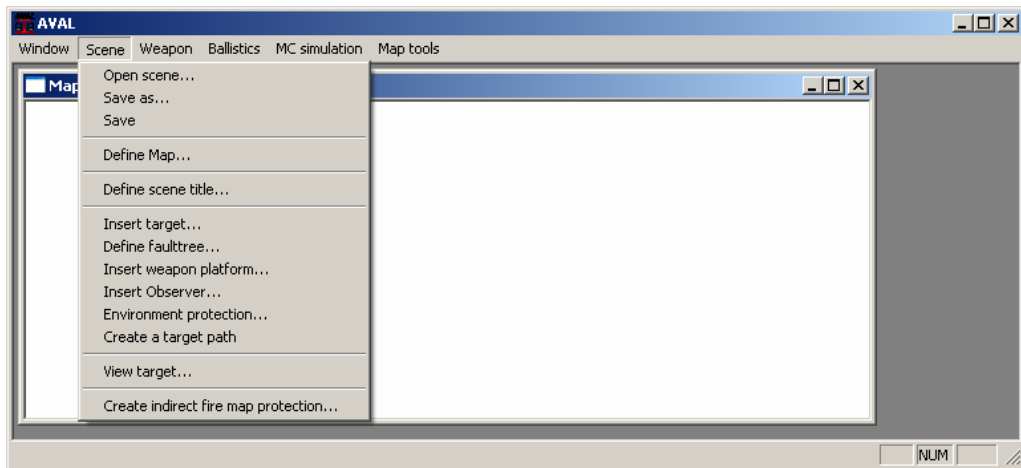

Figure 97 AVAL Indirect fire map menu / Scene.

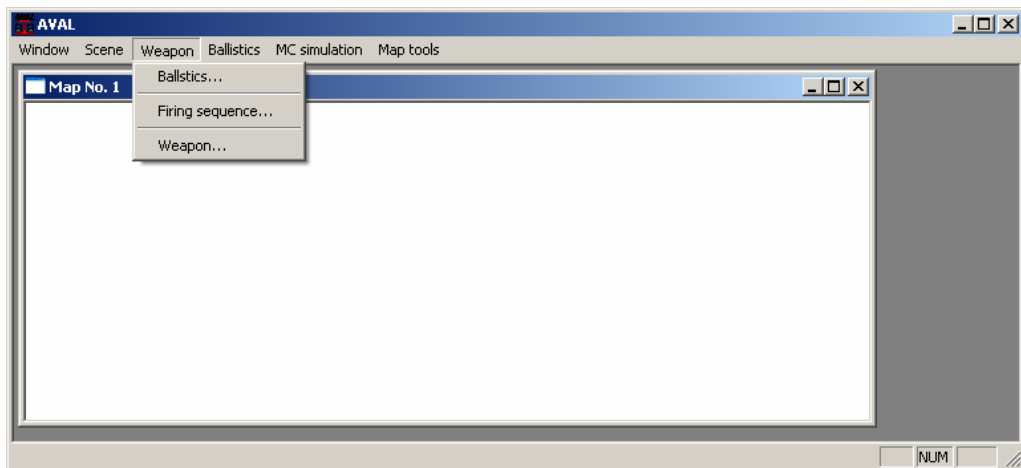

Figure 98: AVAL Indirect fire map menu / Weapon.

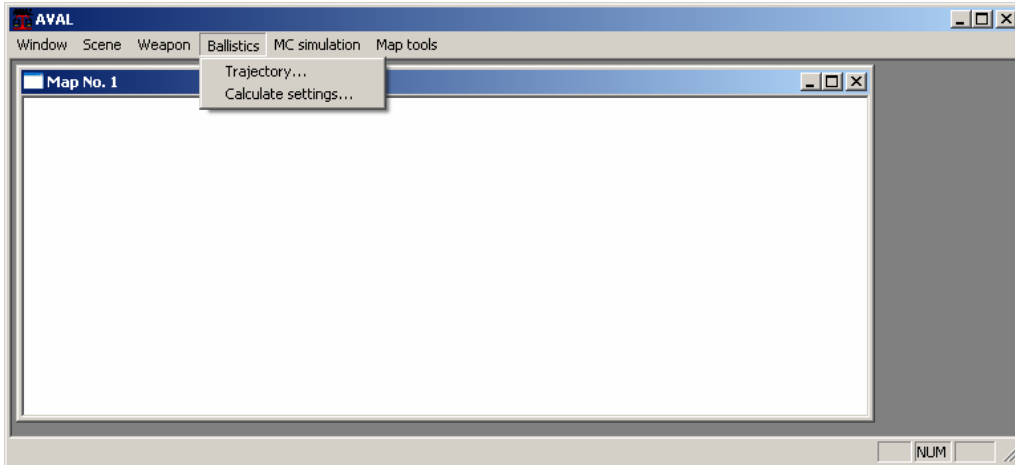

Figure 99 AVAL Indirect fire map menu / Ballistics.

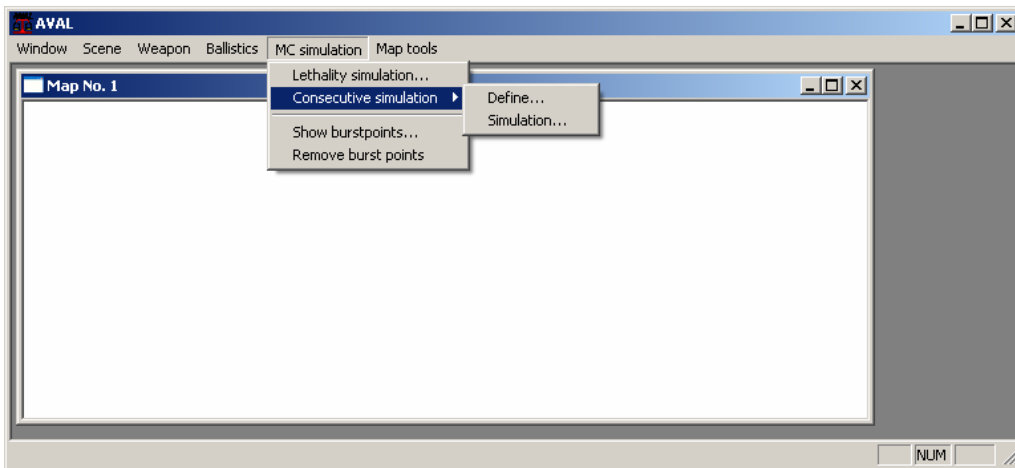

Figure 100 AVAL Indirect fire map menu / MC Simulation / Consecutive simulation.

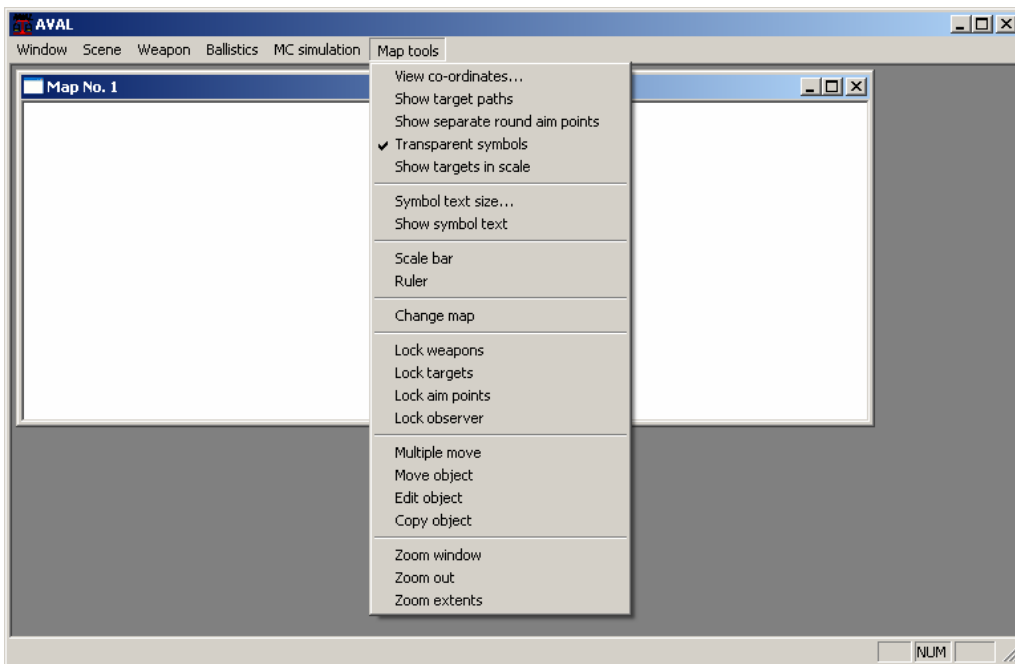

Figure 101 AVAL Indirect fire map menu / Map tools.

12.4 Direct fire scene menu options

Figure 102 -Figure 110 shows all information in AVAL's Direct fire scene menus.

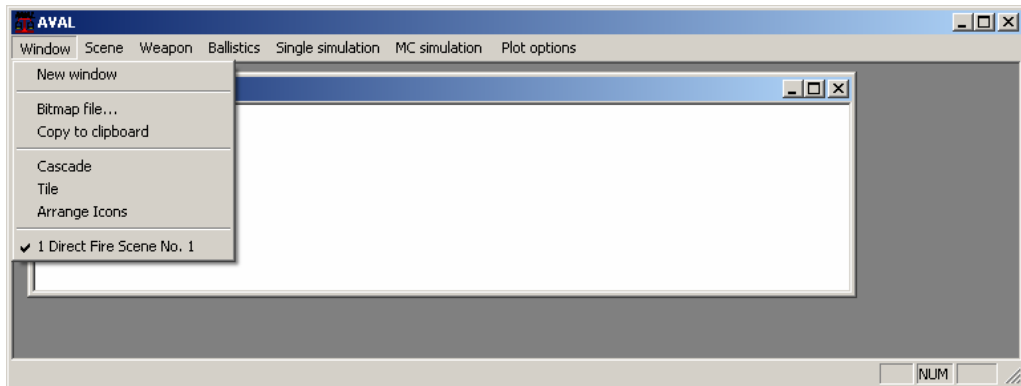

Figure 102 AVAL Direct fire scene menu / Window.

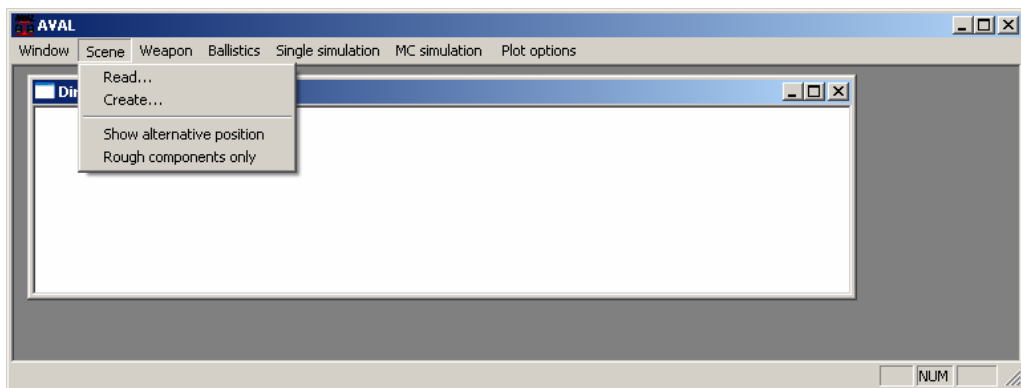

Figure 103 AVAL Direct fire scene menu / Scene.

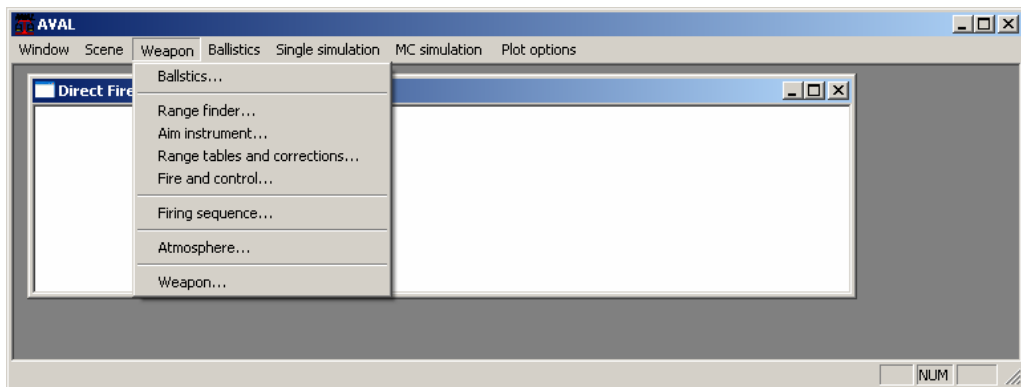

Figure 104 AVAL Direct fire scene menu / Weapon.

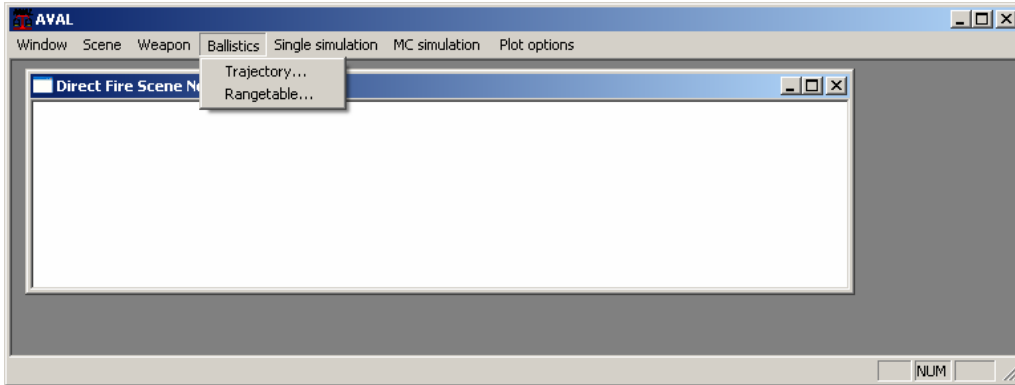

Figure 105 AVAL Direct fire scene menu / Ballistics.

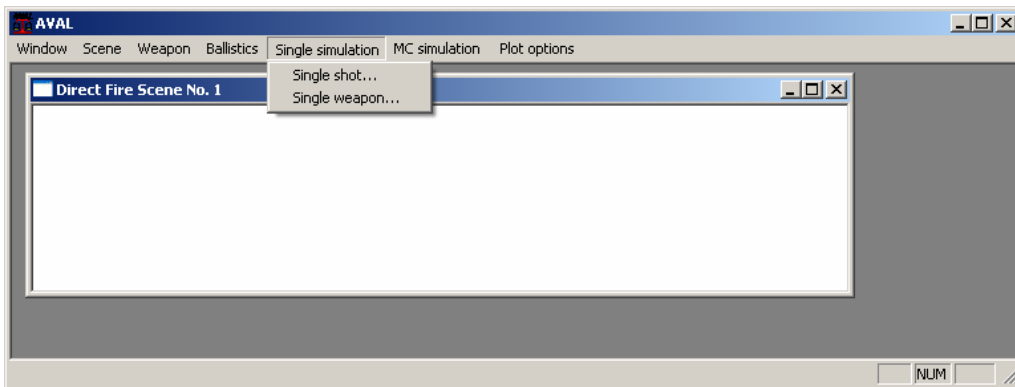

Figure 106 AVAL Direct fire scen menu / Single simulation.

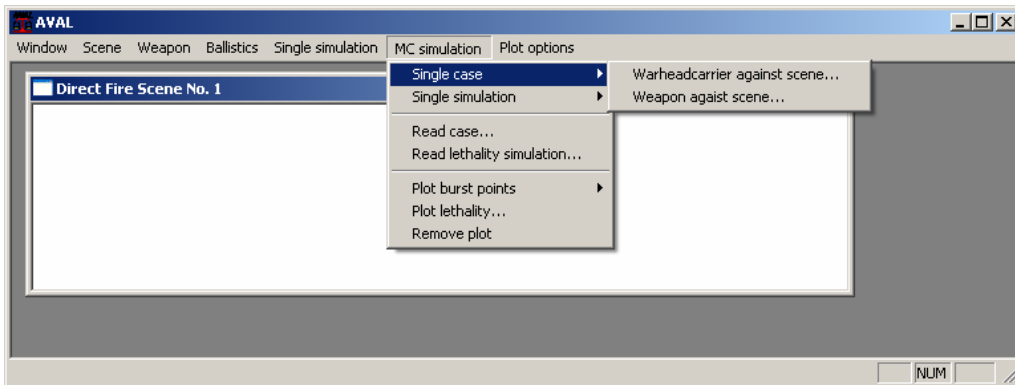

Figure 107 AVAL Direct fire scene menu / MC Simulation / Single case.

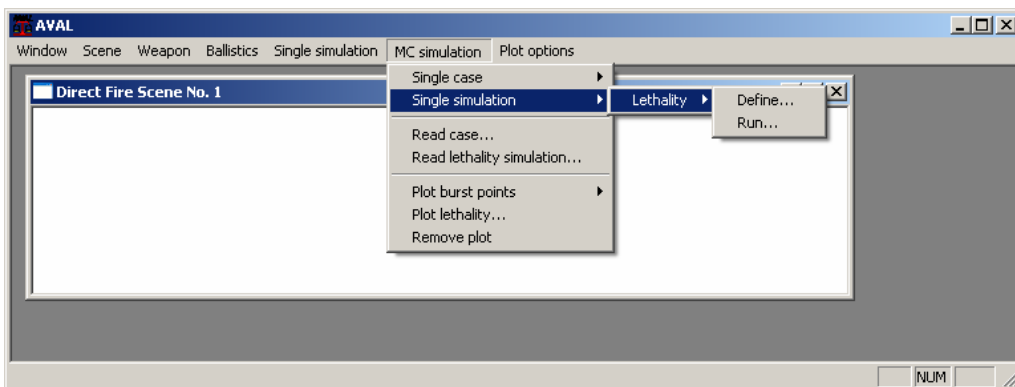

Figure 108 AVAL Direct fire scene menu / MC Simulation / Single simuation / Lethality.

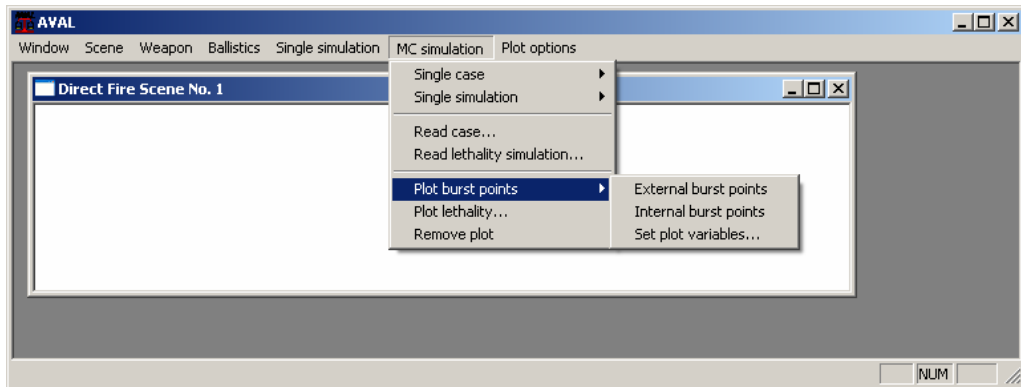

Figure 109 AVAL Direct fire scene menu / MC simulation / Plot burst points.

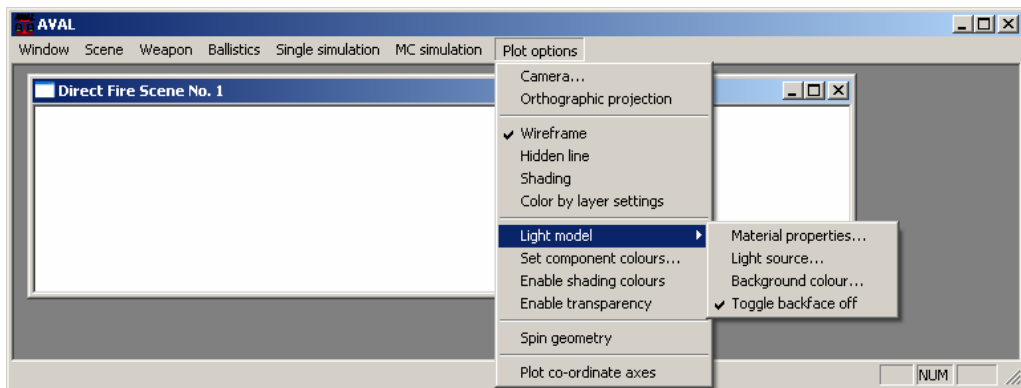

Figure 110 AVAL Direct fire scene menu / Plot options / Light model.

12.5 Mine field map menu options

Figure 111 - Figure 113 shows all AVAL Mine field map menu options.

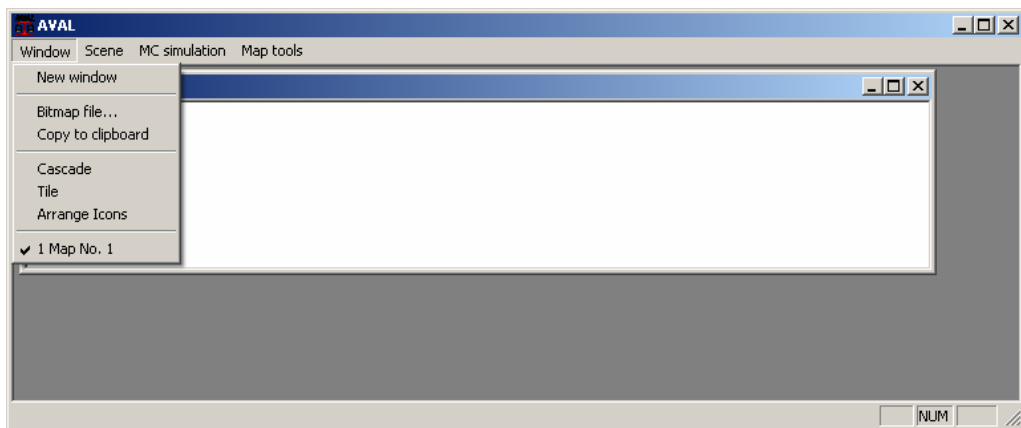

Figure 111 AVAL Mine field map menu / Window.

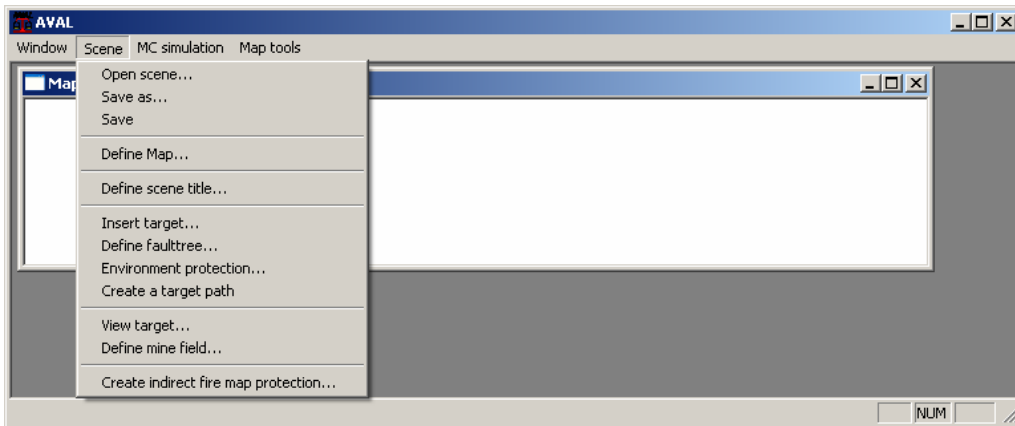

Figure 1121 AVAL Mine field map menu / Scene.

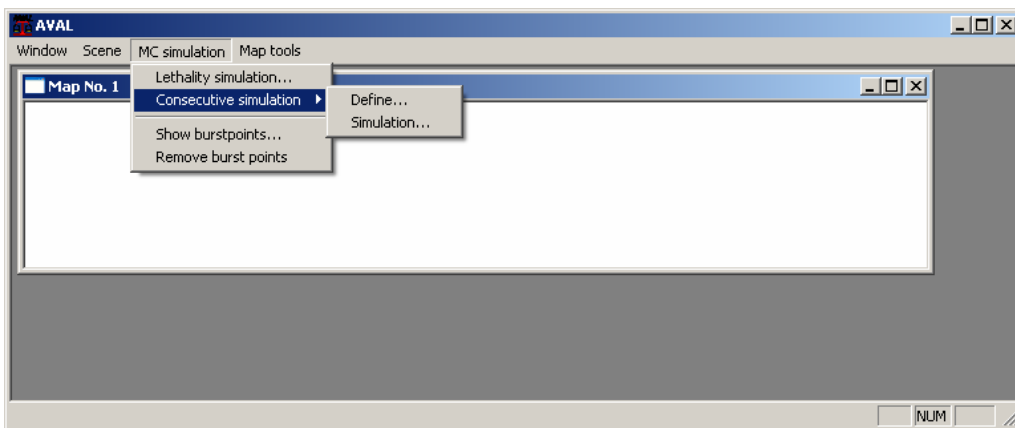

Figure 112 AVAL Mine field map menu / MC simulation / Consecutive simulation.

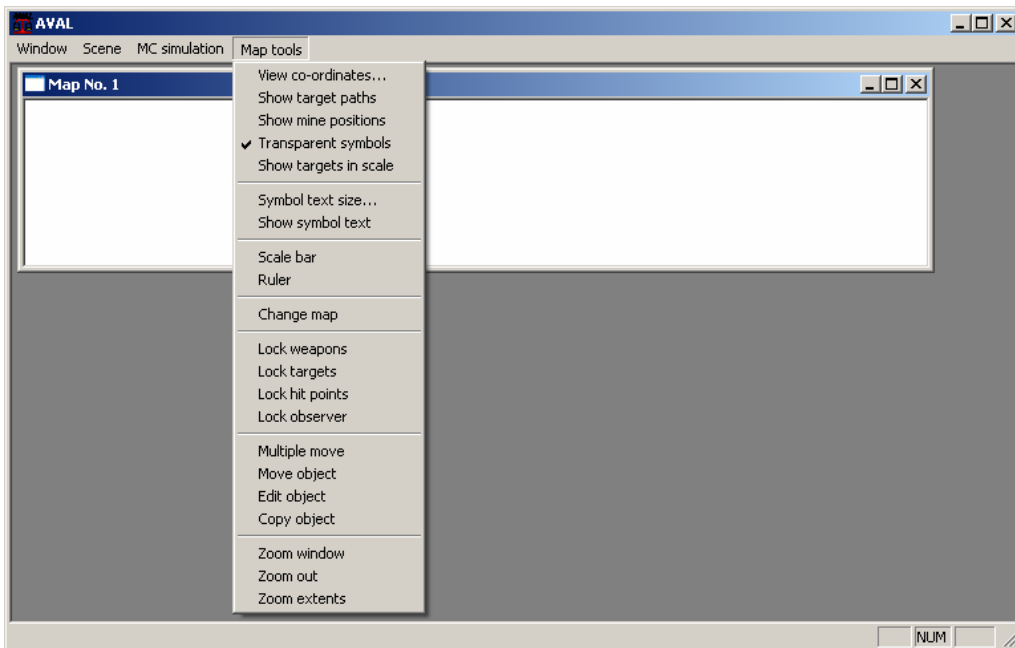

Figure 1133 AVAL Mine field map menu / Map tools.

